

性能曲线

2900rpm

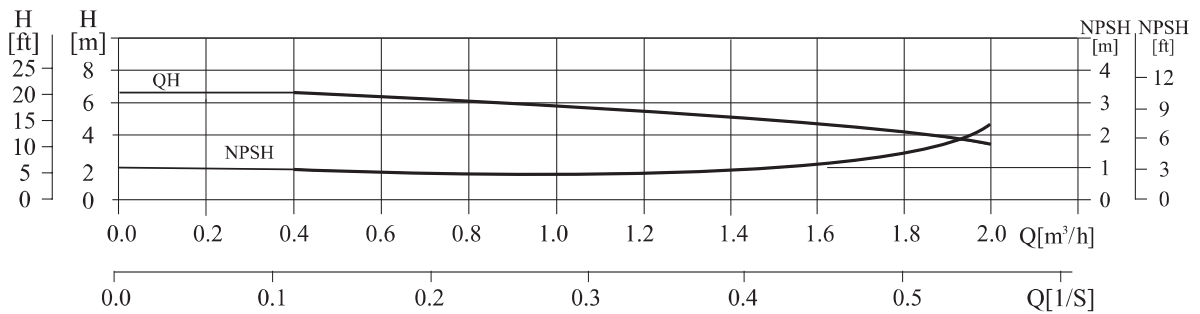
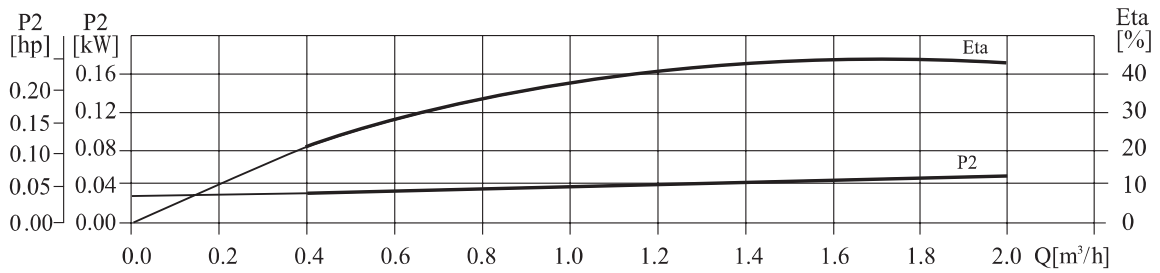
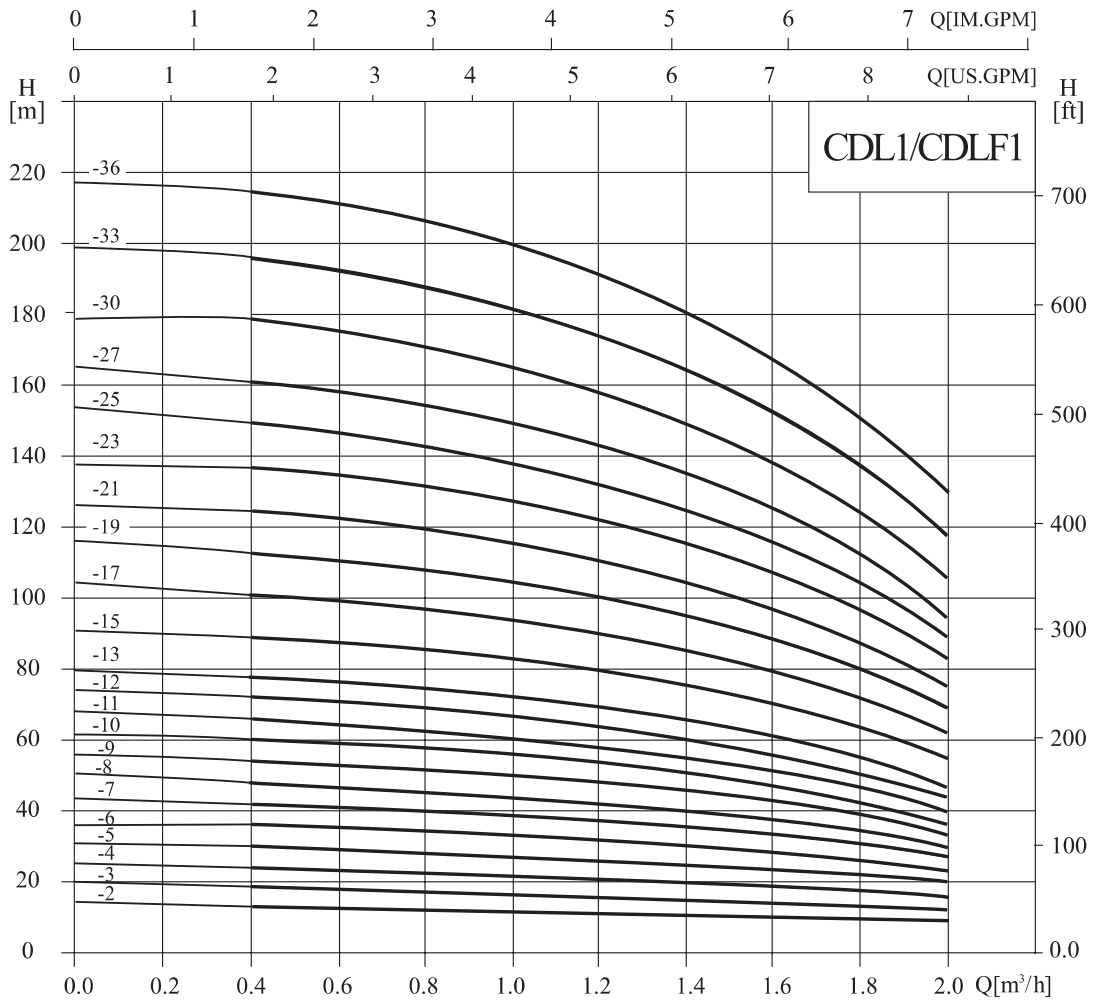

技术数据

性能表

型号	配用电动机 (kW)	Q (m ³ /h)	0.4	0.6	0.8	1.0	1.2	1.4	1.6	1.8	2.0
CDL1-2	0.37	H (m)	13	12.5	12	11.5	11	10.5	10	9.5	9
CDL1-3	0.37		19	18	17.5	17	16.5	16	15	14	12
CDL1-4	0.37		24	23.5	23	22.5	21.5	21	19	18	16
CDL1-5	0.37		30	29.6	29	28	27	26	24	22	20
CDL1-6	0.37		36	35.5	35	33.5	33	31	28	26	23
CDL1-7	0.37		42	41	40.5	39	38	36	33	30	27
CDL1-8	0.55		48	47	46	45	43	41	38	34	30
CDL1-9	0.55		54	53	52	51	49	46	43	39	33
CDL1-10	0.55		60	59	58	57	54	51	48	43	36
CDL1-11	0.55		66	65	63	61	59	56	52	47	40
CDL1-12	0.75		72	71	69	67	64	61	57	51	44
CDL1-13	0.75		78	77	75	73	69	66	62	55	47
CDL1-15	0.75		89	88	86	84	79	76	71	63	55
CDL1-17	1.1		101	99	97	95	89	86	80	71	62
CDL1-19	1.1		113	110	108	106	99	96	89	79	69
CDL1-21	1.1		124	122	120	117	110	106	98	87	75
CDL1-23	1.1		137	133	131	128	121	116	107	96	82
CDL1-25	1.5		149	145	143	139	131	126	116	104	89
CDL1-27	1.5		161	157	155	150	141	136	125	112	95
CDL1-30	1.5		178	175	171	166	157	150	139	124	106
CDL1-33	2.2		196	192	188	183	173	165	154	137	118
CDL1-36	2.2		214	210	205	200	190	181	169	151	130

安装图

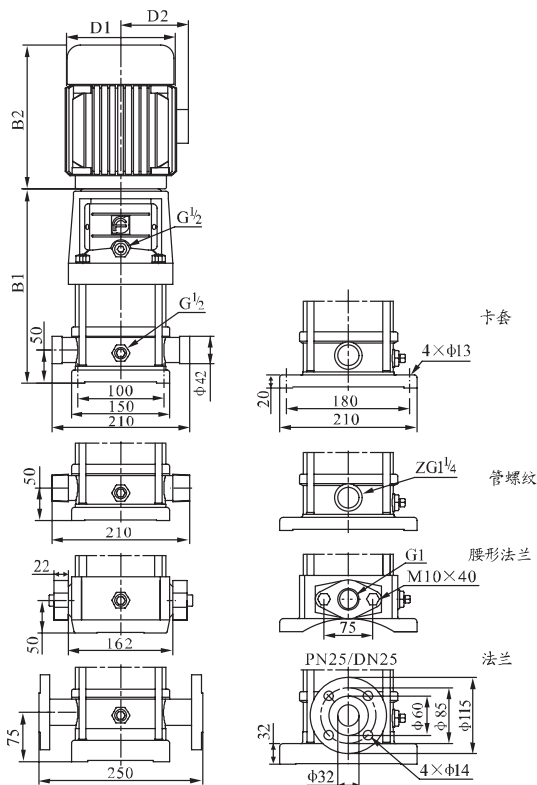

尺寸和重量

型号	尺寸(mm)					重量(kg)
	B1	B2	B1+B2	D1	D2	
CDL1-2	258	225	483	148	117	20
CDL1-3	276	225	501	148	117	20
CDL1-4	294	225	519	148	117	21
CDL1-5	312	225	537	148	117	21
CDL1-6	330	225	555	148	117	22
CDL1-7	348	225	573	148	117	23
CDL1-8	366	225	591	148	117	24
CDL1-9	384	225	609	148	117	25
CDL1-10	402	225	627	148	117	26
CDL1-11	420	225	645	148	117	26
CDL1-12	448	245	693	170	142	29
CDL1-13	466	245	711	170	142	30
CDL1-15	502	245	747	170	142	31
CDL1-17	538	245	783	170	142	33
CDL1-19	574	245	819	170	142	34
CDL1-21	610	245	855	170	142	35
CDL1-23	646	245	891	170	142	36
CDL1-25	692	290	982	190	155	42
CDL1-27	728	290	1018	190	155	43
CDL1-30	782	290	1072	190	155	45
CDL1-33	836	290	1126	190	155	49
CDL1-36	890	290	1180	190	155	51

CDL1-25~1-36无腰形法兰型管路联接
单相电机、隔爆电机外形尺寸有所变动，详情请咨询本公司。

性能曲线

2900rpm

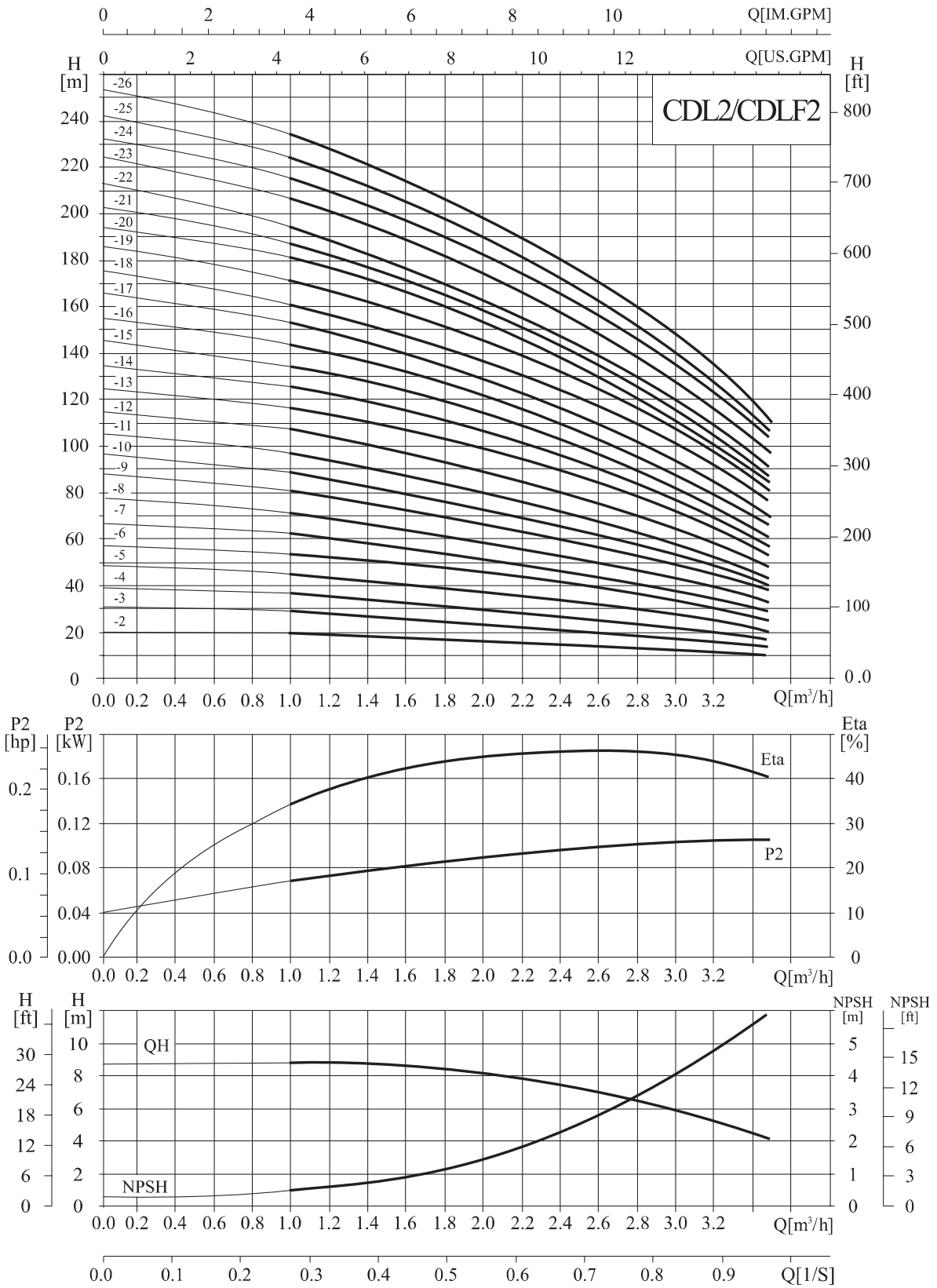

技术数据

性能表

型号	配用电机 (kW)	Q (m ³ /h)	1	1.2	1.6	2.0	2.4	2.8	3.2	3.5
CDL2-2	0.37	H (m)	18	17	16	15	13	12	10	8
CDL2-3	0.37		27	26	24	22	20	18	15	12
CDL2-4	0.55		36	35	33	30	26	24	20	16
CDL2-5	0.55		45	43	40	37	33	30	24	20
CDL2-6	0.75		53	52	50	45	40	36	30	24
CDL2-7	0.75		63	61	57	52	47	41	35	28
CDL2-9	1.1		80	78	73	67	61	54	45	37
CDL2-11	1.1		98	95	89	82	73	64	54	44
CDL2-13	1.5		116	114	106	98	89	78	65	52
CDL2-15	1.5		134	130	123	112	100	90	73	60
CDL2-18	2.2		161	157	148	136	121	108	91	76
CDL2-22	2.2		197	192	180	165	148	130	110	90
CDL2-26	3.0		232	228	214	198	179	158	130	110

安装图

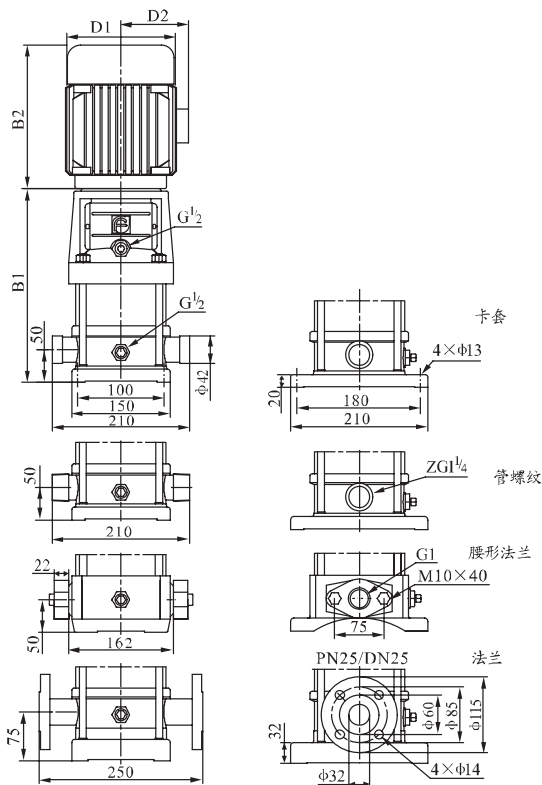

尺寸和重量

型号	尺寸(mm)					重量(kg)
	B1	B2	B1+B2	D1	D2	
CDL2-2	258	225	483	148	117	20
CDL2-3	276	225	501	148	117	20
CDL2-4	294	225	519	148	117	22
CDL2-5	312	225	537	148	117	23
CDL2-6	340	245	585	170	142	26
CDL2-7	358	245	603	170	142	26
CDL2-9	394	245	639	170	142	28
CDL2-11	430	245	675	170	142	29
CDL2-13	476	290	766	190	155	35
CDL2-15	512	290	802	190	155	36
CDL2-18	566	290	856	190	155	41
CDL2-22	638	290	928	190	155	42
CDL2-26	720	345	1065	197	165	52

CDL2-18~2-26无腰形法兰型管路联接
单相电机、隔爆电机外形尺寸有所变动，详情请咨询本公司。

性能曲线

2900rpm

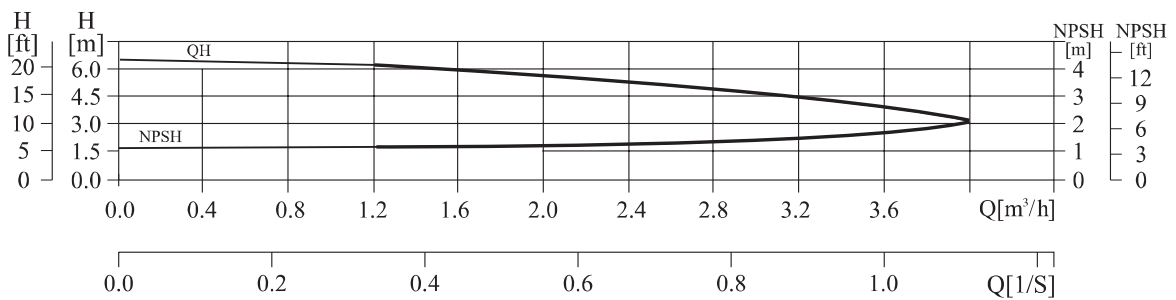
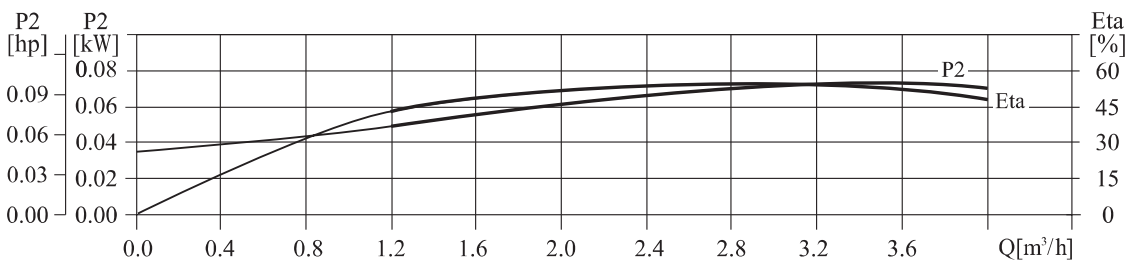
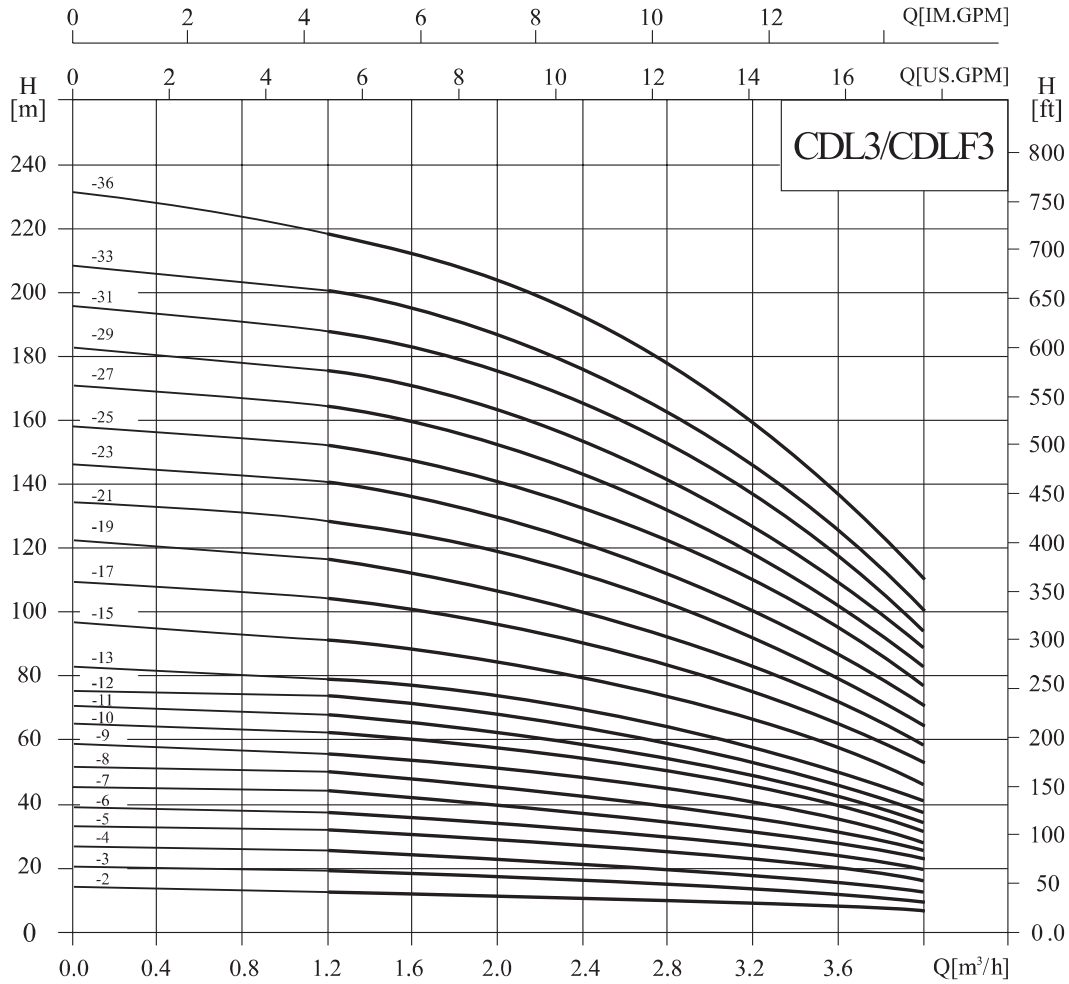

技术数据

性能表

型号	配用电动机 (kW)	Q (m ³ /h)	1.2	1.6	2.0	2.4	2.8	3.0	3.2	3.6	4.0
CDL3-2	0.37	H (m)	12.5	11.5	11	10.5	10	9	8	7	6
CDL3-3	0.37		19	18.5	17.5	16.5	15	14	13	11	9
CDL3-4	0.37		25	24	23	21.5	20	19	18	15	12
CDL3-5	0.37		31	30	29	27	25	23	22	19	16
CDL3-6	0.55		36	35	34	32	30	28	27	23	19
CDL3-7	0.55		43	41	39	37	34	32	31	27	22
CDL3-8	0.75		49	47	45	43	39	37	35	31	25
CDL3-9	0.75		55	53	51	48	45	42	40	35	28
CDL3-10	0.75		61	59	57	54	50	47	45	39	31
CDL3-11	1.1		67	64	61	58	54	51	49	42	34
CDL3-12	1.1		73	70	67	63	58	55	52	45	37
CDL3-13	1.1		78	76	73	69	64	60	57	49	40
CDL3-15	1.1		90	88	84	79	73	69	66	57	46
CDL3-17	1.5		103	100	96	90	83	79	75	64	52
CDL3-19	1.5		115	112	107	100	92	88	83	72	58
CDL3-21	2.2		128	124	119	112	102	98	91	79	64
CDL3-23	2.2		140	135	130	122	112	107	100	86	70
CDL3-25	2.2		151	147	141	131	122	116	109	94	76
CDL3-27	2.2		164	159	152	143	132	124	117	101	82
CDL3-29	2.2		175	170	163	153	142	133	126	109	88
CDL3-31	3.0		187	182	175	165	153	142	135	116	94
CDL3-33	3.0		199	194	187	176	163	151	145	125	100
CDL3-36	3.0		218	212	204	192	178	168	159	137	109

安装图

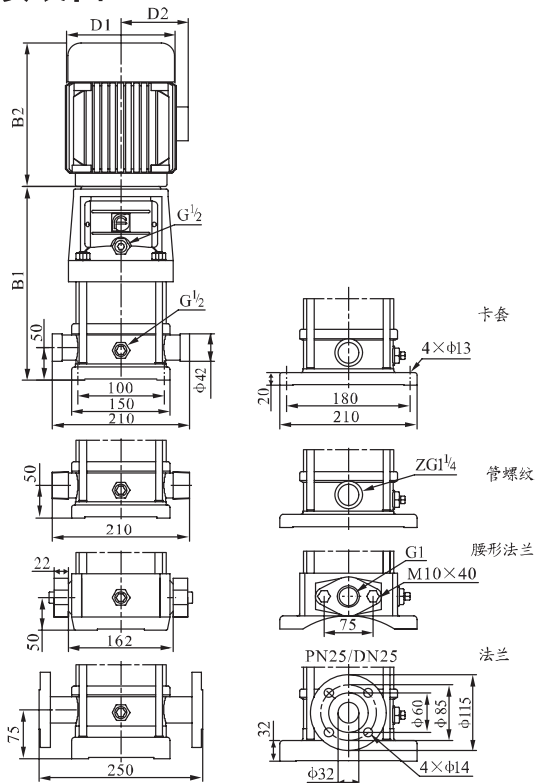

尺寸和重量

型号	尺寸(mm)					重量(kg)
	B1	B2	B1+B2	D1	D2	
CDL3-2	258	225	483	148	117	20
CDL3-3	276	225	501	148	117	20
CDL3-4	294	225	519	148	117	21
CDL3-5	312	225	537	148	117	21
CDL3-6	330	225	555	148	117	23
CDL3-7	348	225	573	148	117	24
CDL3-8	376	245	621	170	142	27
CDL3-9	394	245	639	170	142	28
CDL3-10	412	245	657	170	142	28
CDL3-11	430	245	675	170	142	29
CDL3-12	448	245	693	170	142	30
CDL3-13	466	245	711	170	142	31
CDL3-15	502	245	747	170	142	32
CDL3-17	548	290	838	190	155	38
CDL3-19	584	290	874	190	155	39
CDL3-21	620	290	910	190	155	42
CDL3-23	656	290	946	190	155	43
CDL3-25	692	290	982	190	155	44
CDL3-27	728	290	1018	190	155	45
CDL3-29	764	290	1054	190	155	46
CDL3-31	810	345	1155	197	165	54
CDL3-33	846	345	1191	197	165	55
CDL3-36	900	345	1245	197	165	57

CDL3-25~3-36无腰形法兰型管路联接
单相电机、隔爆电机外形尺寸有所变动，详情请咨询本公司。

性能曲线

2900rpm

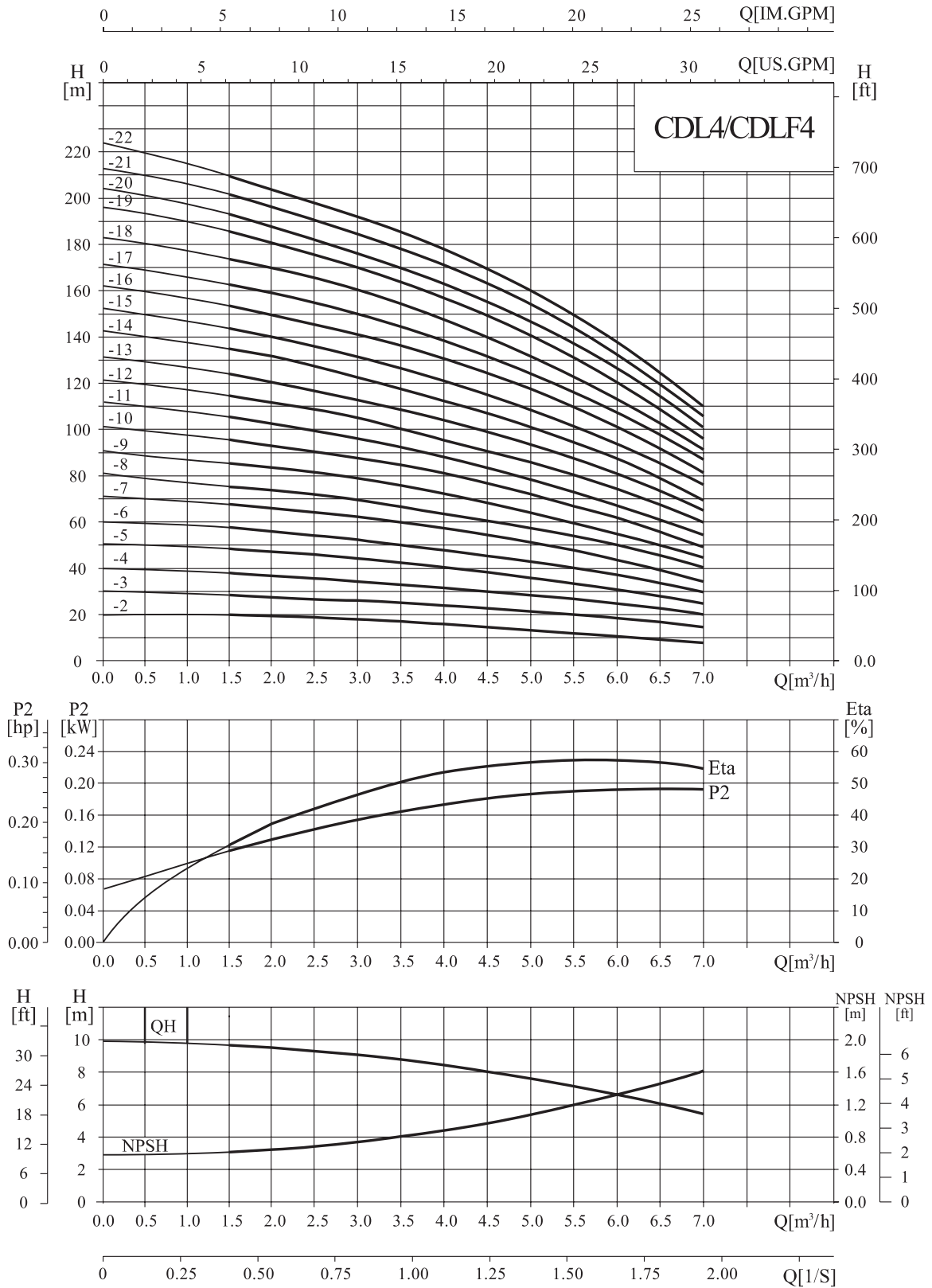

技术数据

性能表

型号	配用电机 (kW)	Q (m ³ /h)	1.5	2.0	3.0	4.0	5.0	6.0	7.0
CDL4-2	0.37	H (m)	19	18	17	15	13	10	8
CDL4-3	0.55		28	27	26	24	20	18	13
CDL4-4	0.75		38	36	34	32	27	24	19
CDL4-5	1.1		47	45	43	40	34	31	23
CDL4-6	1.1		56	54	52	48	41	37	28
CDL4-7	1.5		66	63	61	56	48	43	33
CDL4-8	1.5		74	72	70	64	55	50	38
CDL4-10	2.2		96	90	87	81	71	62	48
CDL4-12	2.2		114	108	104	95	85	75	58
CDL4-14	3.0		136	126	122	112	101	89	68
CDL4-16	3.0		152	144	140	129	115	101	78
CDL4-19	4.0		183	171	168	153	137	122	93
CDL4-22	4.0		211	200	192	178	160	138	108

安装图

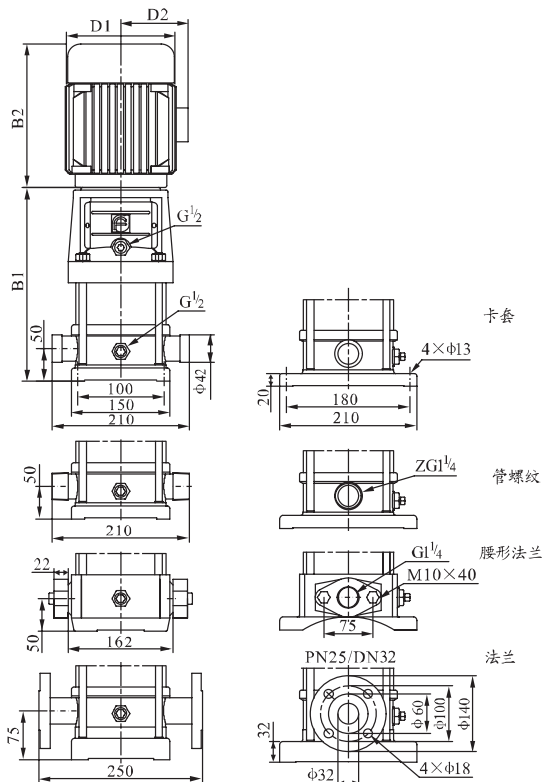

尺寸和重量

型号	尺寸(mm)					重量(kg)
	B1	B2	B1+B2	D1	D2	
CDL4-2	276	225	501	148	117	21
CDL4-3	303	225	528	148	117	22
CDL4-4	340	245	585	170	142	25
CDL4-5	367	245	612	170	142	27
CDL4-6	394	245	639	170	142	27
CDL4-7	431	290	721	190	155	33
CDL4-8	458	290	748	190	155	33
CDL4-10	512	290	802	190	155	37
CDL4-12	566	290	856	190	155	38
CDL4-14	630	345	975	197	165	46
CDL4-16	684	345	1029	197	165	48
CDL4-19	765	355	1120	230	188	57
CDL4-22	846	355	1201	230	188	59

CDL4-19~4-22无腰形法兰型管路联接
单相电机、隔爆电机外形尺寸有所变动，详情请咨询本公司。

性能曲线

2900rpm

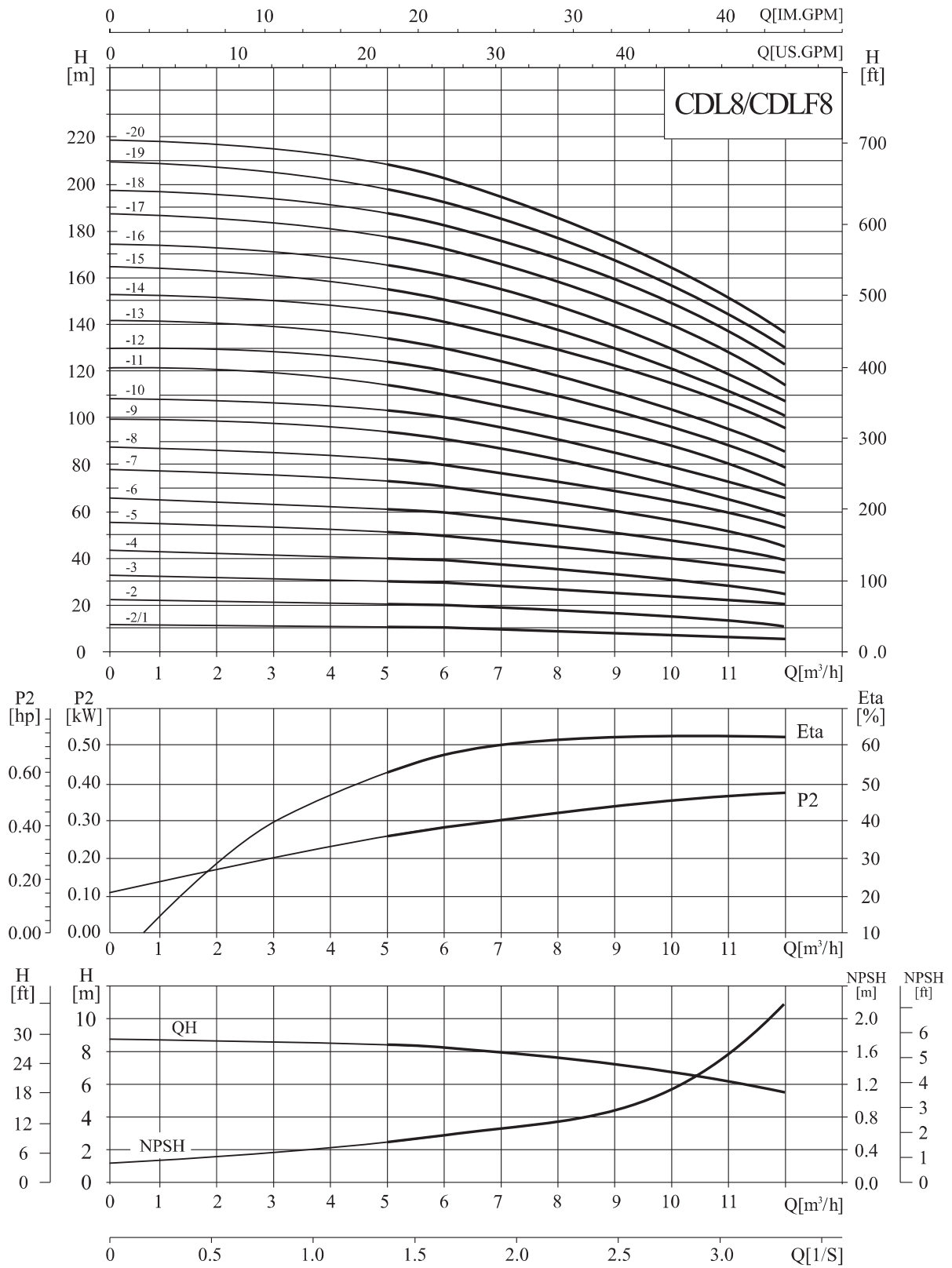

技术数据

性能表

型号	配用电机 (kW)	Q (m ³ /h)	5	6	7	8	9	10	11	12
CDL8-2/1	0.75	H (m)	10	9.5	9.3	9	8.5	8	7	6
CDL8-2	0.75		20	19.5	19	18	17	16	14	13
CDL8-3	1.1		30	29.5	28.5	27	25	24	21	19
CDL8-4	1.5		41	39.5	38	36	34	32	28	26
CDL8-5	2.2		52	50	48	45	42	40	36	32
CDL8-6	2.2		62	60	57	54	51	48	43	39
CDL8-8	3.0		83	80	77	73	69	65	58	52
CDL8-10	4.0		104	100	97	92	87	81	73	65
CDL8-12	4.0		124	120	116	111	104	92	87	78
CDL8-14	5.5		145	141	136	130	122	113	102	92
CDL8-16	5.5		166	161	156	148	139	130	118	106
CDL8-18	7.5		187	182	175	167	157	146	134	120
CDL8-20	7.5		208	202	195	186	175	163	150	135

安装图

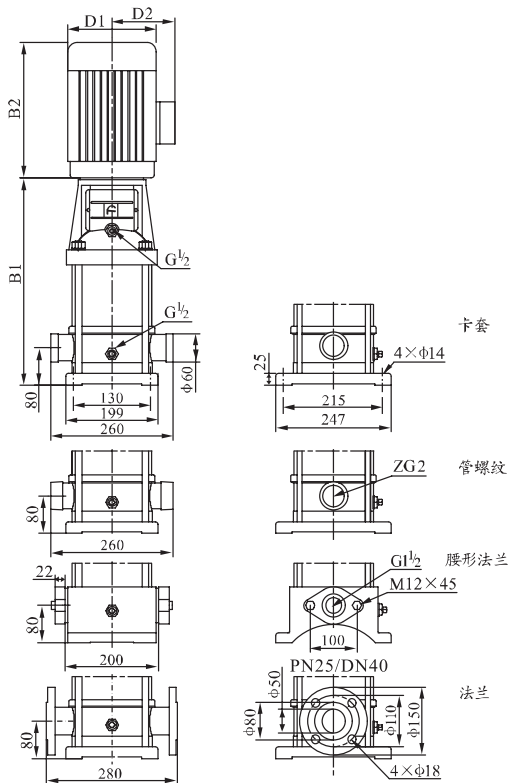

尺寸和重量

型号	尺寸(mm)					重量(kg)
	B1	B2	B1+B2	D1	D2	
CDL8-2/1	347	245	592	170	142	32
CDL8-2	347	245	592	170	142	32
CDL8-3	377	245	622	170	142	34
CDL8-4	417	290	707	190	155	40
CDL8-5	447	290	737	190	155	44
CDL8-6	477	290	767	190	155	45
CDL8-8	547	345	892	197	165	53
CDL8-10	607	355	962	230	188	64
CDL8-12	667	355	1022	230	188	66
CDL8-14	747	390	1137	260	208	81
CDL8-16	807	390	1197	260	208	84
CDL8-18	867	390	1257	260	208	93
CDL8-20	927	390	1317	260	208	94

CDL8-14~8-20无腰形法兰型管路联接
单相电机、隔爆电机外形尺寸有所变动，详情请咨询本公司。

性能曲线

2900rpm

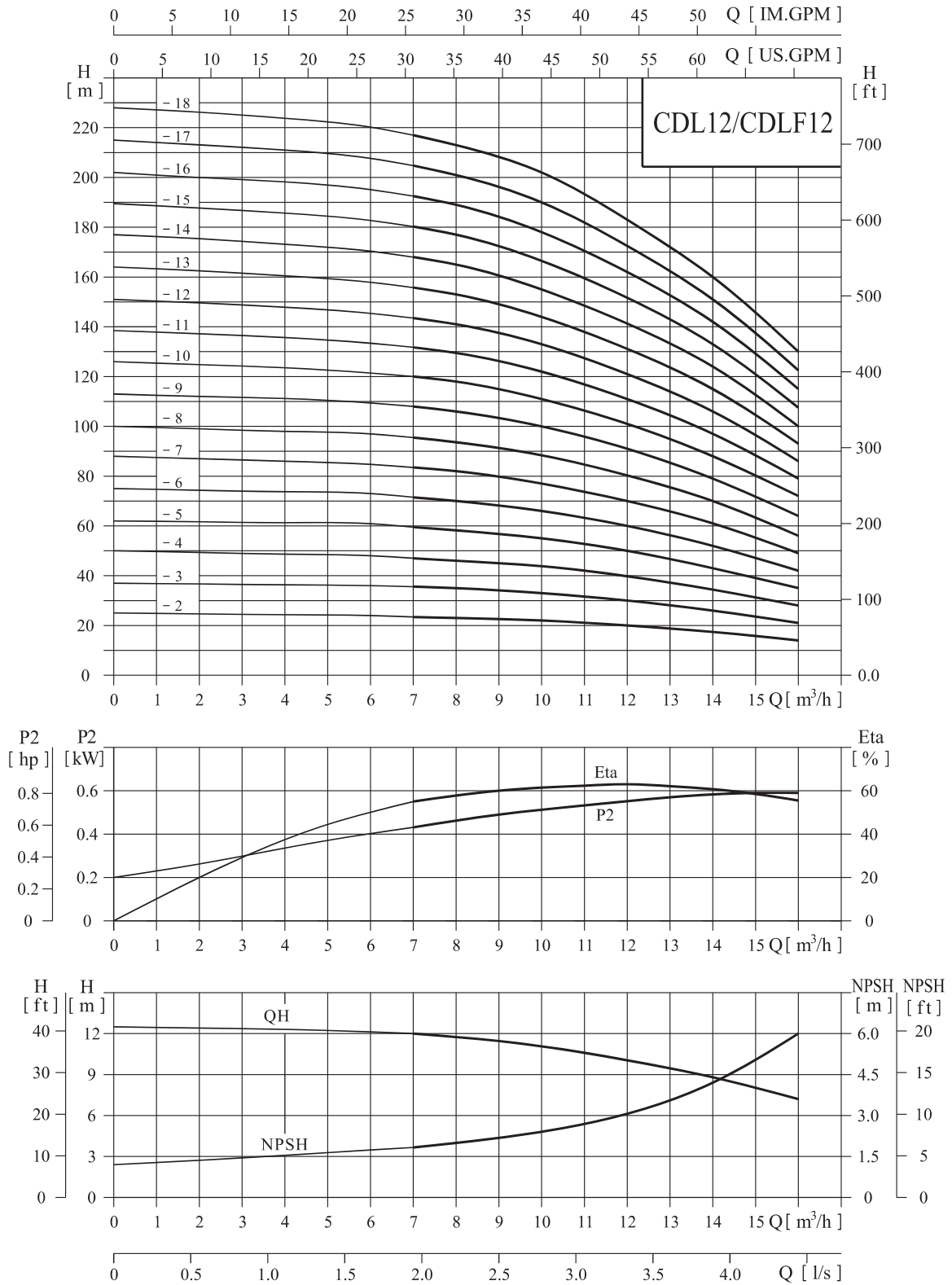

技术数据

性能表

型号	配用电机 (kW)	Q (m ³ /h)	7	8	9	10	11	12	13	14	15	16
CDL12-2	1.5	H (m)	23.5	23	22.5	22	21	20	18.5	17	15.5	14
CDL12-3	2.2		35.5	35	34	33	31.5	30	28	26	23.5	21
CDL12-4	3		47	46	45	44	42	40	37	34	31	28
CDL12-5	3		59.5	58	56.5	55	52.5	50	46.5	43	39	35
CDL12-6	4		71.5	70	68	66	63	60	56	52	47	42
CDL12-7	5.5		83.5	82	79.5	77	73.5	70	65.5	61	55	49
CDL12-8	5.5		95.5	94	91	88	84	80	75	70	63	56
CDL12-9	5.5		108	106	103	100	95.5	91	85	79	71.5	64
CDL12-10	7.5		120	118	114.5	111	106	101	94.5	88	80	72
CDL12-12	7.5		143.5	141	137	133	127	121	113.5	106	96	86
CDL12-14	11		168	165	160	155	148	141	132.5	124	112	100
CDL12-16	11		192.5	189	183.5	178	170	162	152	142	128.5	115
CDL12-18	11		217	213	207.5	202	192.5	183	171.5	160	145	130

安装图

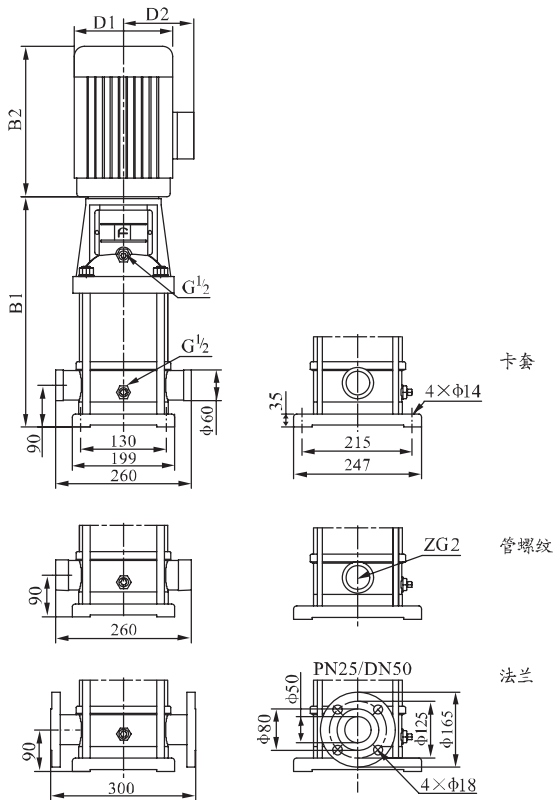

尺寸和重量

型号	尺寸(mm)					重量(kg)
	B1	B2	B1+B2	D1	D2	
CDL12-2	367	290	657	190	155	39
CDL12-3	397	290	687	190	155	43
CDL12-4	437	345	782	197	165	51
CDL12-5	467	345	812	197	165	53
CDL12-6	497	355	852	230	188	61
CDL12-7	547	390	937	260	208	73
CDL12-8	577	390	967	260	208	74
CDL12-9	607	390	997	260	208	76
CDL12-10	637	390	1027	260	208	83
CDL12-12	697	390	1087	260	208	87
CDL12-14	845	500	1345	330	255	157
CDL12-16	905	500	1405	330	255	161
CDL12-18	965	500	1465	330	255	164

单相电机、隔爆电机外形尺寸有所变动，详情请咨询本公司。

性能曲线

2900rpm

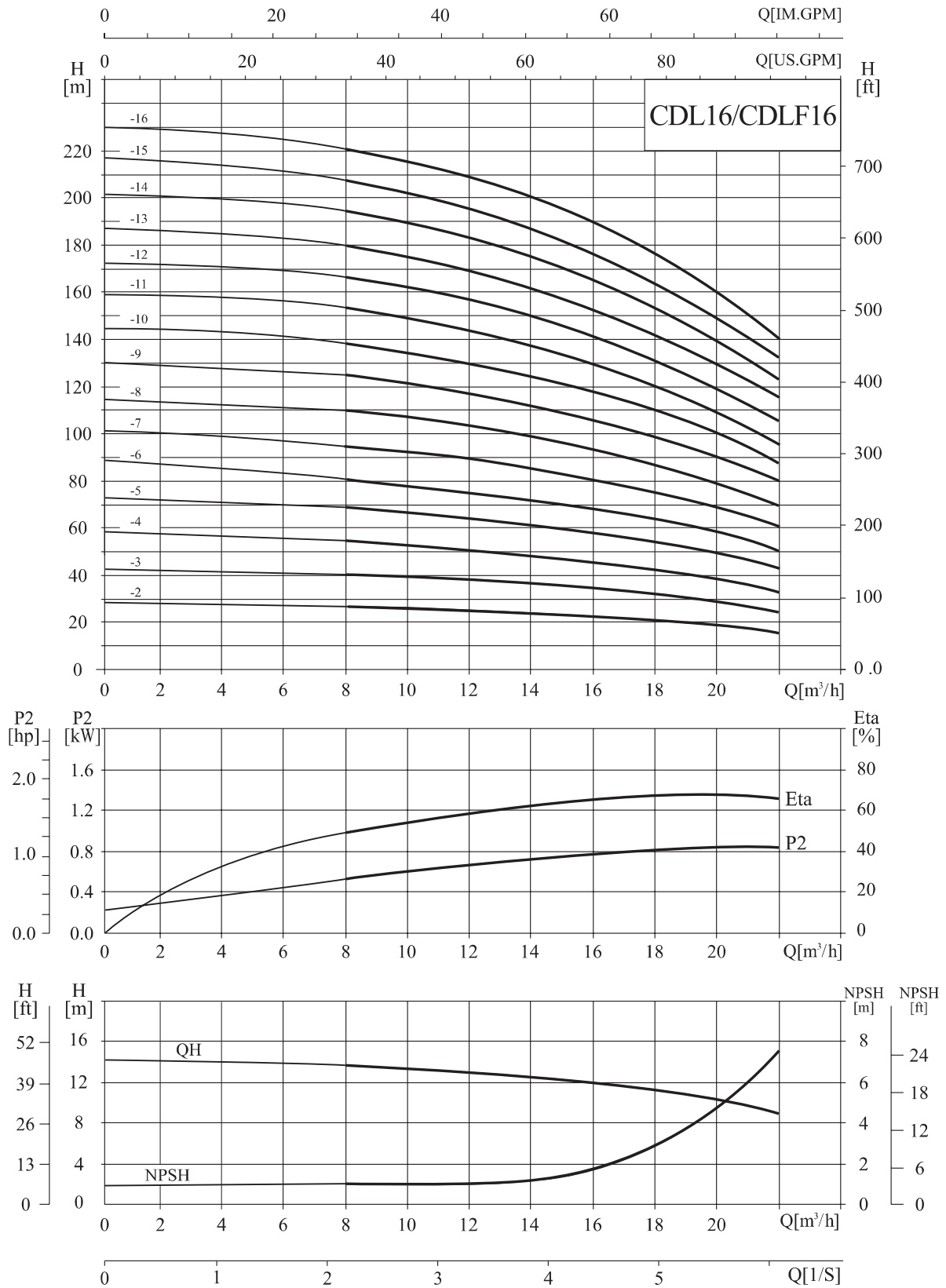

技术数据

性能表

型号	配用电机 (kW)	Q (m ³ /h)	8	10	12	14	16	18	20	22
CDL16-2	2.2	H (m)	27	26	25	24	22	21	19	16
CDL16-3	3.0		41	40	38	37	34	32	29	25
CDL16-4	4.0		54	53	52	49	46	43	38	34
CDL16-5	5.5		68	67	65	62	58	54	48	43
CDL16-6	5.5		82	80	78	74	70	64	58	52
CDL16-7	7.5		96	95	91	87	82	76	68	61
CDL16-8	7.5		110	108	104	99	94	86	77	70
CDL16-10	11		138	136	131	125	118	109	97	87
CDL16-12	11		166	162	157	150	141	130	116	105
CDL16-14	15		194	190	184	175	166	152	136	122
CDL16-16	15		222	217	210	200	189	174	156	140

安装图

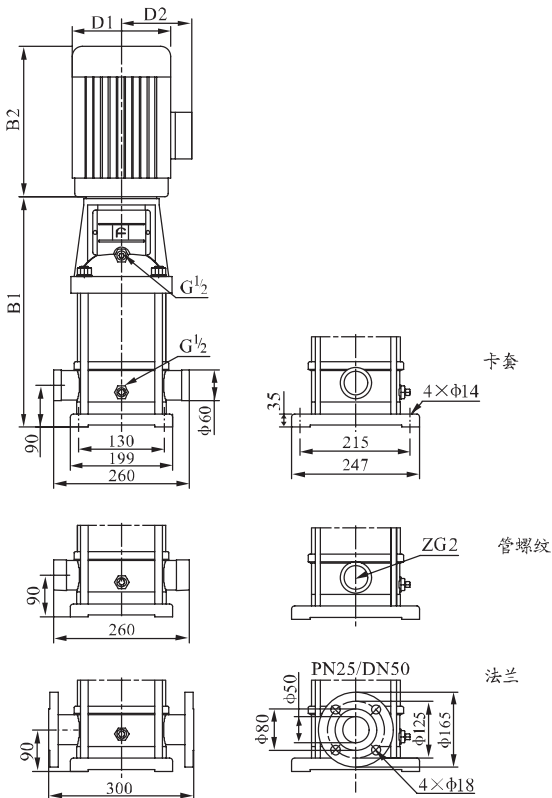

尺寸和重量

型号	尺寸(mm)					重量(kg)
	B1	B2	B1+B2	D1	D2	
CDL16-2	397	290	687	190	155	42
CDL16-3	452	345	797	197	165	50
CDL16-4	497	355	852	230	188	59
CDL16-5	562	390	952	260	208	76
CDL16-6	607	390	997	260	208	77
CDL16-7	652	390	1042	260	208	84
CDL16-8	697	390	1087	260	208	86
CDL16-10	875	500	1375	330	255	158
CDL16-12	965	500	1465	330	255	161
CDL16-14	1055	500	1555	330	255	174
CDL16-16	1145	500	1645	330	255	178

单相电机、隔爆电机外形尺寸有所变动，详情请咨询本公司。

性能曲线

2900rpm

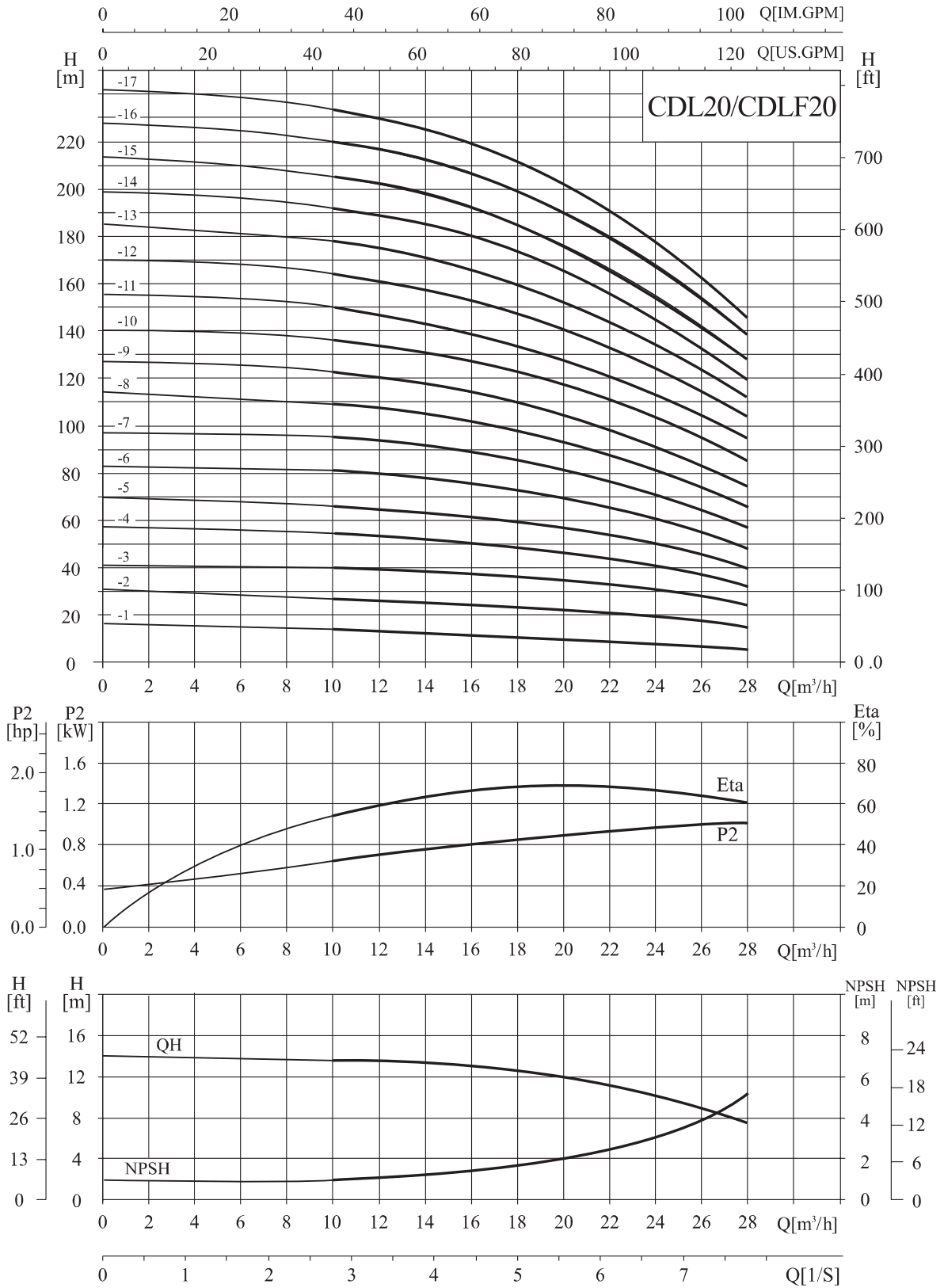

技术数据

性能表

型号	配用电机 (kW)	Q (m ³ /h)	10	12	14	16	18	20	22	24	26	28
CDL20-1	1.1	H (m)	13.5	13	12.5	12	11	10	9	8	7	6
CDL20-2	2.2		27	26.5	26	25	24	23	22	20	18	15
CDL20-3	4.0		40	39.5	39	38	37	35	33	30	27	24
CDL20-4	5.5		54	53	52	51	49	47	44	41	37	33
CDL20-5	5.5		67	66	64	62	60	58	55	50	45	40
CDL20-6	7.5		81	79	77	75	73	70	66	61	55	49
CDL20-7	7.5		95	93	91	89	86	82	77	71	65	58
CDL20-8	11		109	107	105	102	99	94	89	82	75	67
CDL20-10	11		136	134	131	128	124	118	111	103	95	85
CDL20-12	15		164	162	158	154	149	142	133	124	114	102
CDL20-14	15		192	189	185	180	174	166	156	145	133	119
CDL20-17	18.5		234	230	225	219	212	202	190	177	162	145

安装图

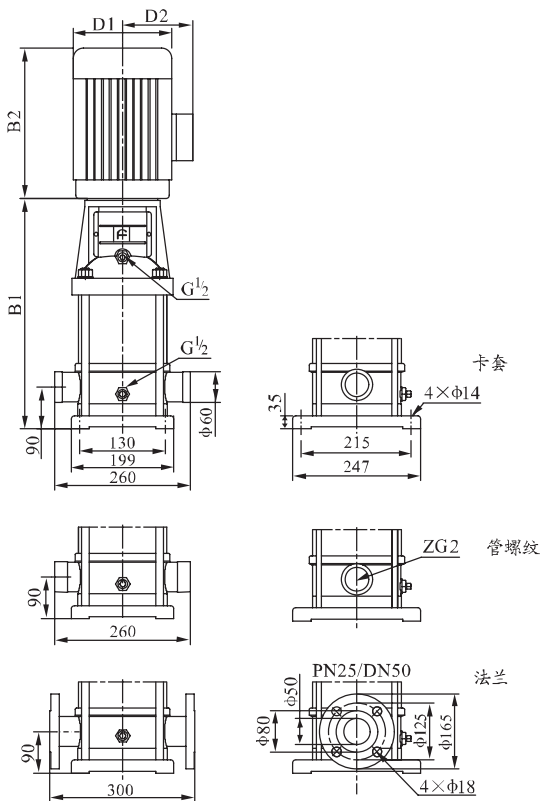

尺寸和重量

型号	尺寸(mm)					重量(kg)
	B1	B2	B1+B2	D1	D2	
CDL20-1	387	245	632	170	142	33
CDL20-2	397	290	687	190	155	42
CDL20-3	452	355	807	230	188	58
CDL20-4	517	390	907	260	208	74
CDL20-5	562	390	952	260	208	76
CDL20-6	607	390	997	260	208	82
CDL20-7	652	390	1042	260	208	84
CDL20-8	785	500	1285	330	255	153
CDL20-10	875	500	1375	330	255	157
CDL20-12	965	500	1465	330	255	170
CDL20-14	1055	500	1555	330	255	172
CDL20-17	1190	550	1740	330	255	195

单相电机、隔爆电机外形尺寸有所变动，详情请咨询本公司。

性能曲线

2900rpm

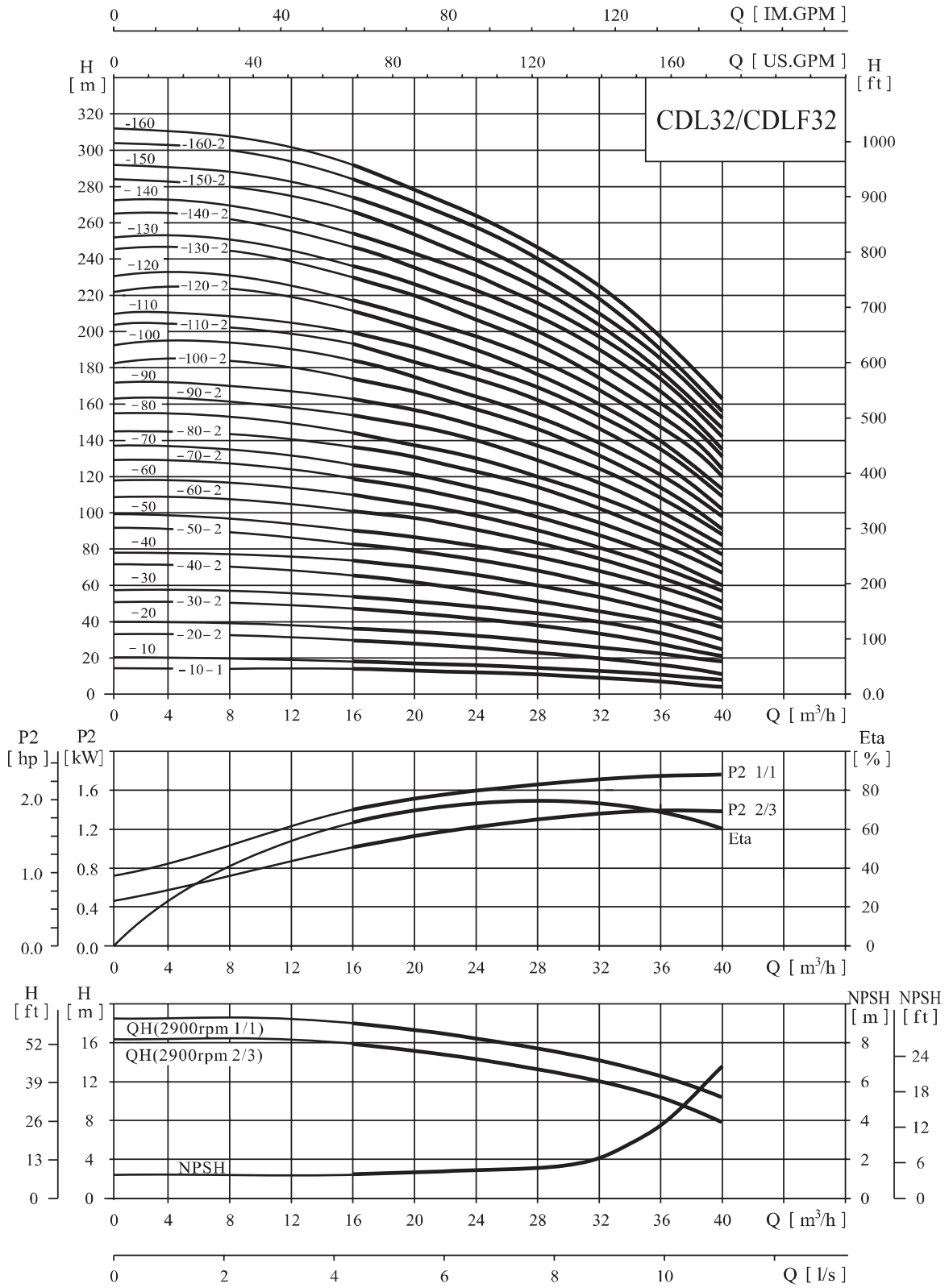

技术数据

性能表

型号	配用电机 (kW)	Q (m³/h)	H (m)							型号	配用电机 (kW)	Q (m³/h)	H (m)						
			16	20	24	28	32	36	40				16	20	24	28	32	36	40
CDL32-10-1	1.5	H (m)	14	13	12	11	9	7	4	CDL32-90-2	18.5	H (m)	154	148	140	129	117	102	82
CDL32-10	2.2		18	17	15	14	13	11	8	CDL32-90	18.5		162	156	147	136	124	109	88
CDL32-20-2	3.0		29	28	26	23	20	16	11	CDL32-100-2	18.5		175	166	157	146	131	115	91
CDL32-20	4.0		36	34	32	29	27	23	18	CDL32-100	18.5		182	173	164	152	138	122	98
CDL32-30-2	5.5		47	44	41	38	33	28	21	CDL32-110-2	22		193	184	173	164	146	128	102
CDL32-30	5.5		54	51	48	44	40	35	27	CDL32-110	22		200	191	180	168	153	135	109
CDL32-40-2	7.5		65	62	58	53	46	40	30	CDL32-120-2	22		211	201	189	178	160	140	113
CDL32-40	7.5		72	69	65	59	53	47	37	CDL32-120	22		218	208	196	184	167	147	120
CDL32-50-2	11		83	79	74	68	60	52	41	CDL32-130-2	30		230	218	206	193	174	153	124
CDL32-50	11		90	86	81	74	67	59	47	CDL32-130	30		237	225	213	200	181	160	131
CDL32-60-2	11		101	97	90	83	74	65	51	CDL32-140-2	30		247	235	222	210	189	165	135
CDL32-60	11		108	104	97	90	81	72	57	CDL32-140	30		255	242	229	216	196	172	142
CDL32-70-2	15		119	114	107	98	88	78	60	CDL32-150-2	30		266	253	239	224	203	178	145
CDL32-70	15		126	121	113	105	95	85	67	CDL32-150	30		274	260	246	231	210	185	152
CDL32-80-2	15		136	131	123	114	102	90	71	CDL32-160-2	30		284	270	255	240	218	190	156
CDL32-80	15		144	138	130	120	109	97	77	CDL32-160	30		292	277	262	246	225	197	163

安装图

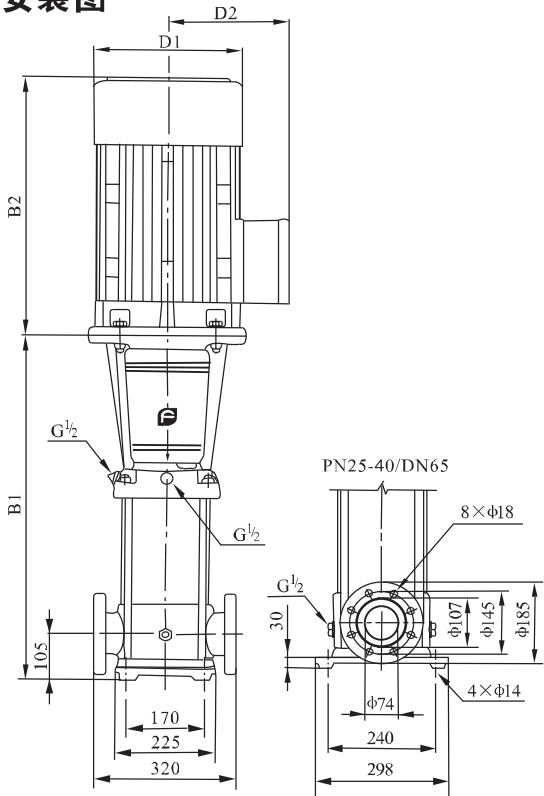

单相电机、隔爆电机外形尺寸有所变动，详情请咨询本公司。

尺寸和重量

型号	尺寸(mm)					重量(kg)
	B1	B2	B1+B2	D1	D2	
CDL32-10-1/CDL32-10	505	290	795	190	155	64/68
CDL32-20-2/CDL32-20	575	345/355	920/930	197/230	165/180	77/85
CDL32-30-2/CDL32-30	645	390	1035	260	208	100
CDL32-40-2/CDL32-40	715	390	1105	260	208	109
CDL32-50-2/CDL32-50	890	500	1390	330	255	181
CDL32-60-2/CDL32-60	960	500	1460	330	255	185
CDL32-70-2/CDL32-70	1030	500	1530	330	255	199
CDL32-80-2/CDL32-80	1100	500	1600	330	255	203
CDL32-90-2/CDL32-90	1170	550	1720	330	255	222
CDL32-100-2/CDL32-100	1240	550	1790	330	255	227
CDL32-110-2/CDL32-110	1310	575	1885	360	285	272
CDL32-120-2/CDL32-120	1380	575	1955	360	285	276
CDL32-130-2/CDL32-130	1450	650	2100	400	310	337
CDL32-140-2/CDL32-140	1520	650	2170	400	310	341
CDL32-150-2/CDL32-150	1590	650	2240	400	310	345
CDL32-160-2/CDL32-160	1660	650	2310	400	310	350

性能曲线

2900rpm

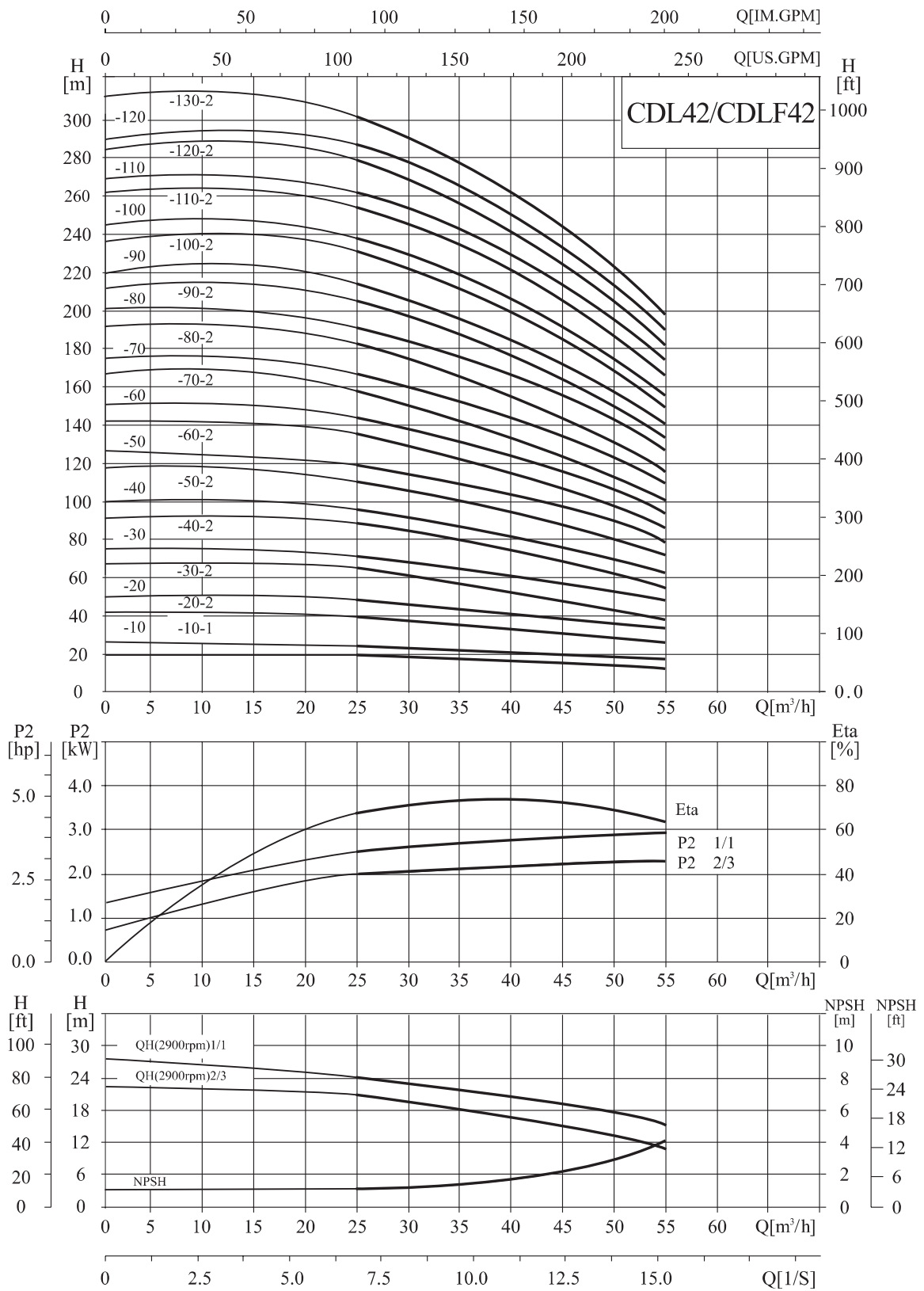

技术数据

性能表

型号	配用电机 (kW)	Q (m ³ /h)	H (m)								
			25	30	35	40	42	45	50	55	
CDL42-10-1	3.0	H (m)	20	19	18	17	16	15	13	11	
CDL42-10	4.0		24	23	22	21	20	19	18	16	
CDL42-20-2	5.5		40	38	36	33	32	30	27	23	
CDL42-20	7.5		48	46	44	42	41	39	35	31	
CDL42-30-2	11		63	61	58	54	52	50	44	38	
CDL42-30	11		71	69	66	63	61	58	53	47	
CDL42-40-2	15		87	84	80	75	73	69	62	54	
CDL42-40	15		95	92	88	84	81	78	71	62	
CDL42-50-2	18.5		111	107	102	96	93	88	80	69	
CDL42-50	18.5		119	115	110	105	101	97	88	78	
CDL42-60-2	22		135	130	124	117	113	108	97	85	
CDL42-60	22		143	138	132	125	122	116	106	93	
CDL42-70-2	30		158	152	146	138	134	127	115	100	
CDL42-70	30		166	161	154	146	142	135	124	109	
CDL42-80-2	30		182	175	168	159	154	146	133	116	
CDL42-80	30		190	184	176	167	162	154	141	124	
CDL42-90-2	30		205	198	190	180	174	166	150	132	
CDL42-90	37		214	207	198	188	183	174	159	140	
CDL42-100-2	37		230	221	212	200	194	185	168	147	
CDL42-100	37		238	230	220	209	203	193	177	155	
CDL42-110-2	45		255	246	236	223	217	206	188	165	
CDL42-110	45		263	255	244	232	225	214	196	173	
CDL42-120-2	45		280	270	259	245	238	226	206	181	
CDL42-120	45		289	280	268	255	247	236	216	190	
CDL42-130-2	45		305	294	282	267	259	247	225	198	

安装图

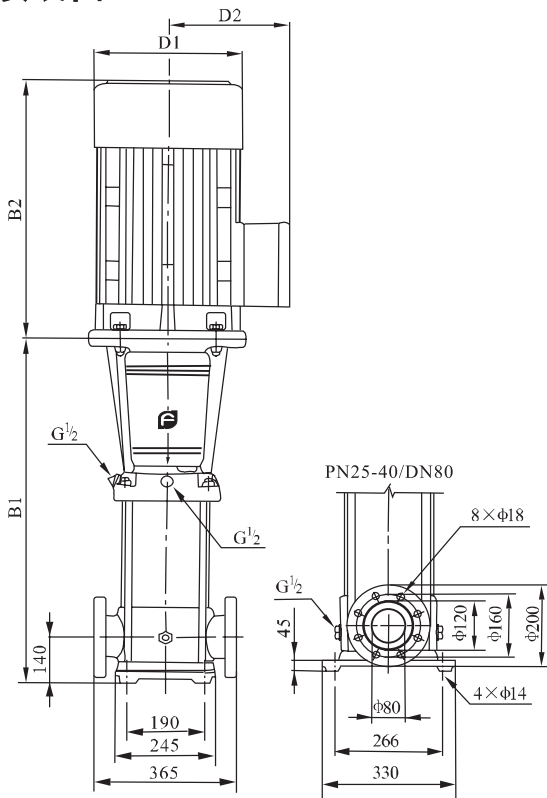

尺寸和重量

型号	尺寸(mm)					重量(kg)
	B1	B2	B1+B2	D1	D2	
CDL42-10-1	561	345/355	906/916	197/230	165/188	83/90
CDL42-10						
CDL42-20-2	641	390	1031	260	208	105/110
CDL42-20						
CDL42-30-2	826	500	1326	330	255	183
CDL42-30						
CDL42-40-2	906	500	1406	330	255	197
CDL42-40						
CDL42-50-2	986	550	1536	330	255	221
CDL42-50						
CDL42-60-2	1066	575	1641	360	285	261
CDL42-60						
CDL42-70-2	1146	650	1796	400	310	320
CDL42-70						
CDL42-80-2	1226	650	1876	400	310	324
CDL42-80						
CDL42-90-2	1306	650	1956	400	310	328/352
CDL42-90						
CDL42-100-2	1386	650	2036	400	310	355
CDL42-100						
CDL42-110-2	1466	685	2151	450	345	426
CDL42-110						
CDL42-120-2	1546	685	2231	450	345	432
CDL42-120						
CDL42-130-2	1626	685	2311	450	345	438

隔爆电机外形尺寸有所变动, 详情请咨询本公司。

性能曲线

2900rpm

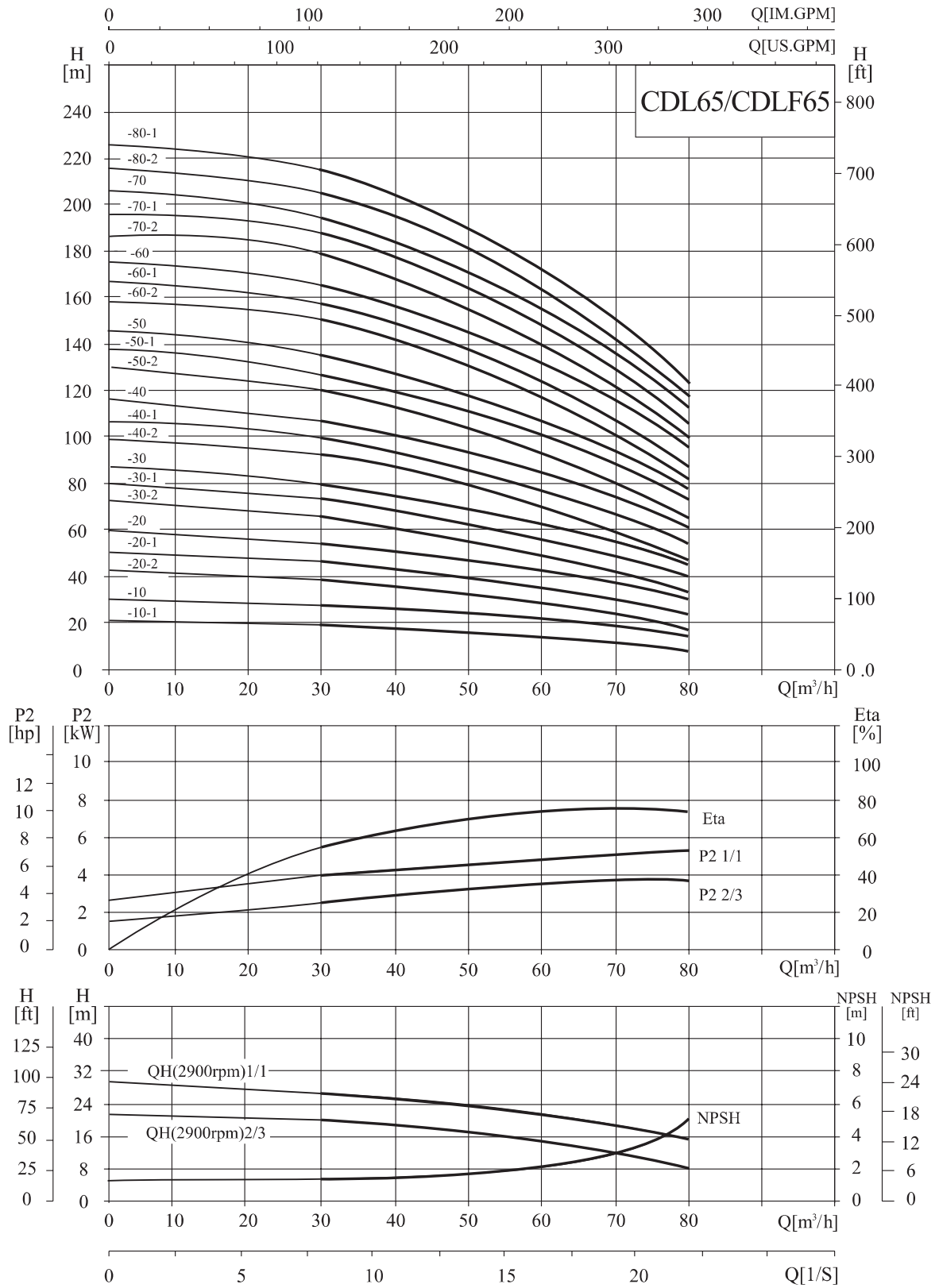

技术数据

性能表

型号	配用电动机 (kW)	Q (m ³ /h)	H (m)							
			30	40	50	60	65	70	80	
CDL65-10-1	4.0	H (m)	19	18	16	14	13	11	8	
CDL65-10	5.5		27	25	23	21	20	18	15	
CDL65-20-2	7.5		39	36	33	29	26	23	17	
CDL65-20-1	11		46	44	40	36	33	30	24	
CDL65-20	11		53	51	47	43	40	37	30	
CDL65-30-2	15		66	62	56	50	46	41	32	
CDL65-30-1	15		73	69	63	57	53	48	39	
CDL65-30	18.5		80	76	70	64	60	55	46	
CDL65-40-2	18.5		92	87	80	71	66	60	47	
CDL65-40-1	22		100	94	87	78	73	67	54	
CDL65-40	22		107	101	94	85	80	74	61	
CDL65-50-2	30		121	114	105	95	88	80	64	
CDL65-50-1	30		128	121	112	102	95	87	71	
CDL65-50	30		136	129	119	109	102	94	78	
CDL65-60-2	30		150	142	131	118	110	101	81	
CDL65-60-1	37		157	149	138	125	117	108	88	
CDL65-60	37		164	156	145	132	124	115	95	
CDL65-70-2	37		179	169	156	141	132	121	99	
CDL65-70-1	37		186	176	163	148	139	128	106	
CDL65-70	45		193	183	170	155	146	135	112	
CDL65-80-2	45		207	196	182	164	154	142	116	
CDL65-80-1	45		215	203	189	171	161	149	123	

安装图

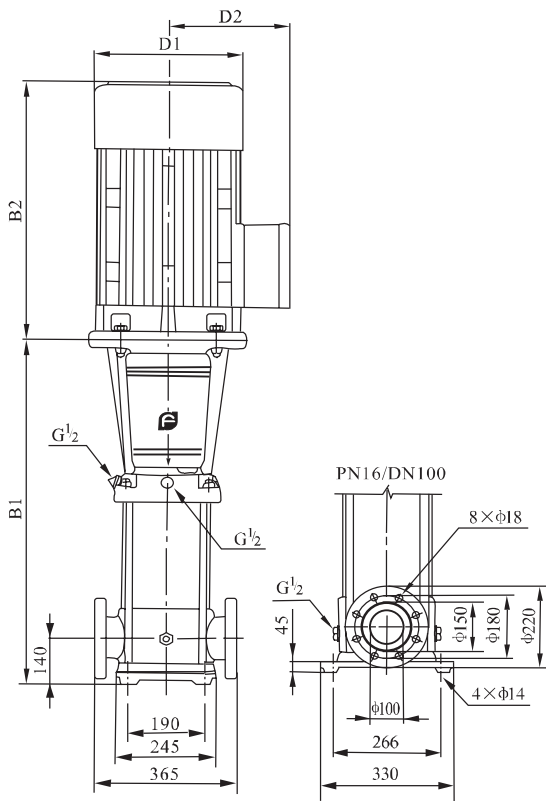

尺寸和重量

型号	尺寸(mm)					重量(kg)
	B1	B2	B1+B2	D1	D2	
CDL65-10-1	561	355	916	230	188	93
CDL65-10	561	390	951	260	208	105
CDL65-20-2	644	390	1034	260	208	110
CDL65-20-1	754	500	1254	330	255	182
CDL65-20	754	500	1254	330	255	182
CDL65-30-2	836	500	1336	330	255	196
CDL65-30-1	836	500	1336	330	255	197
CDL65-30	836	550	1386	330	255	221
CDL65-40-2	919	550	1469	330	255	225
CDL65-40-1	919	575	1494	360	285	258
CDL65-40	919	575	1494	360	285	258
CDL65-50-2	1001	650	1651	400	310	319
CDL65-50-1	1001	650	1651	400	310	319
CDL65-50	1001	650	1651	400	310	320
CDL65-60-2	1084	650	1734	400	310	325
CDL65-60-1	1084	650	1734	400	310	349
CDL65-60	1084	650	1734	400	310	349
CDL65-70-2	1166	650	1816	400	310	353
CDL65-70-1	1166	650	1816	400	310	353
CDL65-70	1166	685	1851	460	340	420
CDL65-80-2	1248	685	1933	460	340	424
CDL65-80-1	1248	685	1933	460	340	424

隔爆电机外形尺寸有所变动, 详情请咨询本公司。
CDL65系列也可按客户要求提供PN25-40/DN100标准法兰。

性能曲线

2900rpm

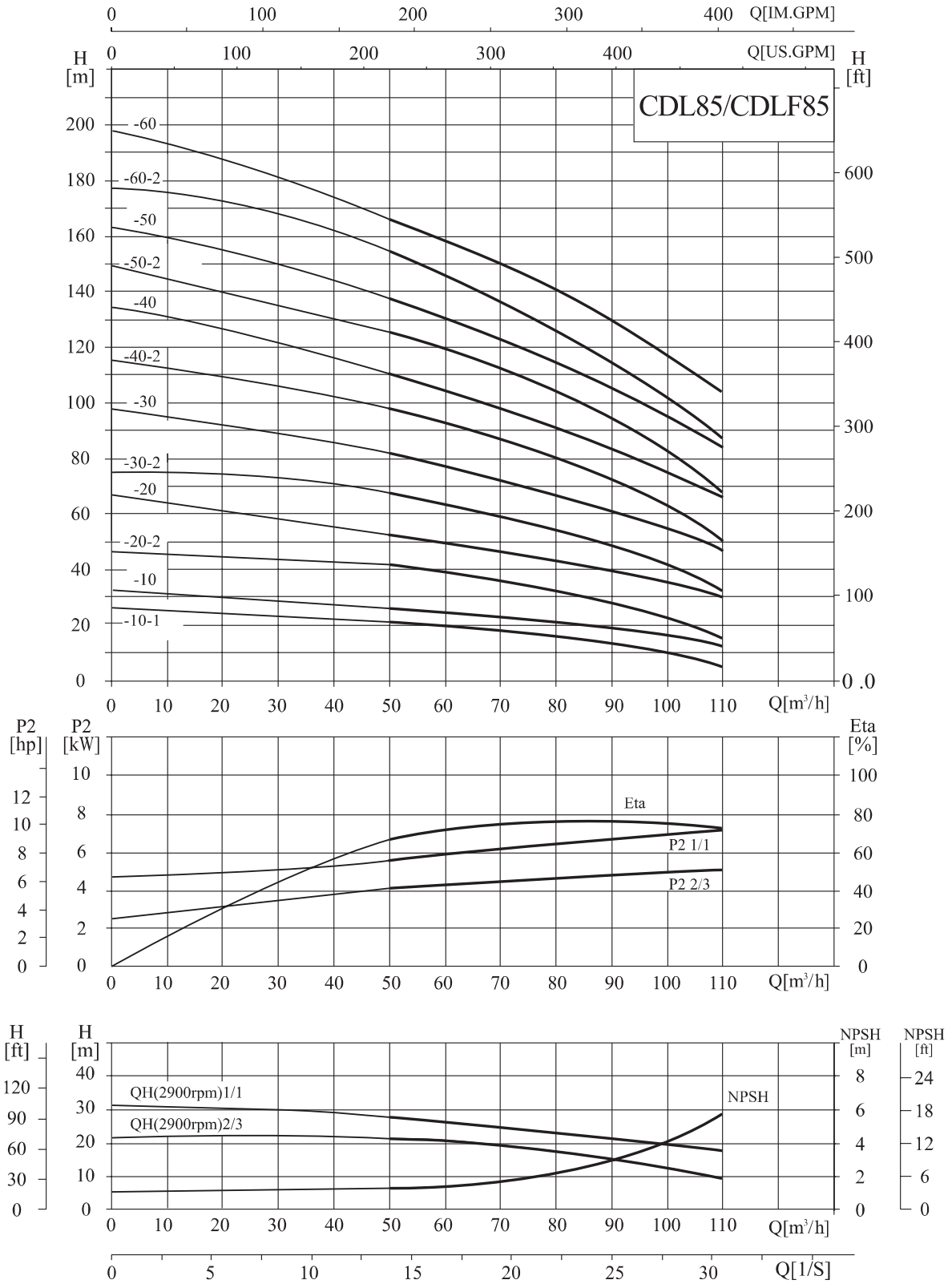

技术数据

性能表

型号	配用电机 (kW)	Q (m ³ /h)	H (m)								
			50	60	70	80	85	90	100	110	
CDL85-10-1	5.5	H (m)	22	19	17	16	14	13	10	6	
CDL85-10	7.5		25	24	22	21	20	19	16	12	
CDL85-20-2	11		41	39	36	32	30	28	22	15	
CDL85-20	15		53	50	47	44	41	40	36	30	
CDL85-30-2	18.5		68	65	60	55	52	49	41	32	
CDL85-30	22		81	77	72	67	64	62	55	48	
CDL85-40-2	30		98	93	87	80	75	72	62	50	
CDL85-40	30		110	105	100	92	86	84	76	66	
CDL85-50-2	37		126	120	113	104	98	93	81	68	
CDL85-50	37		139	131	124	115	110	106	94	83	
CDL85-60-2	45		155	148	139	129	122	117	102	86	
CDL85-60	45		168	160	150	141	134	130	117	103	

安装图

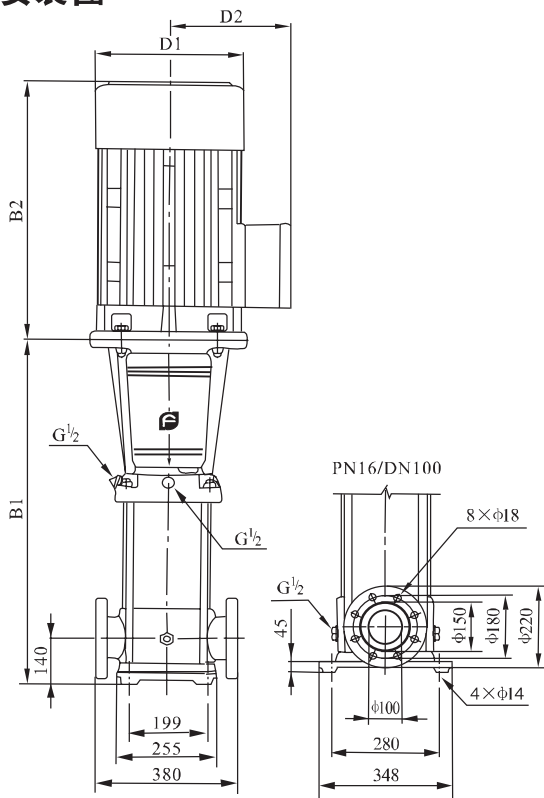

尺寸和重量

型号	尺寸(mm)					重量(kg)
	B1	B2	B1+B2	D1	D2	
CDL85-10-1	571	390	961	260	208	105
CDL85-10	571	390	961	260	208	110
CDL85-20-2	773	500	1273	330	255	181
CDL85-20	773	500	1273	330	255	192
CDL85-30-2	865	550	1415	330	255	215
CDL85-30	865	575	1440	360	285	252
CDL85-40-2	957	650	1607	400	310	312
CDL85-40	957	650	1607	400	310	312
CDL85-50-2	1049	650	1699	400	310	336
CDL85-50	1049	650	1699	400	310	336
CDL85-60-2	1141	685	1826	460	340	407
CDL85-60	1141	685	1826	460	340	407

防爆电机外形尺寸有所变动, 详情请咨询本公司。
CDL85系列也可按客户要求提供PN25-40/DN100标准法兰。

性能曲线

2950rpm

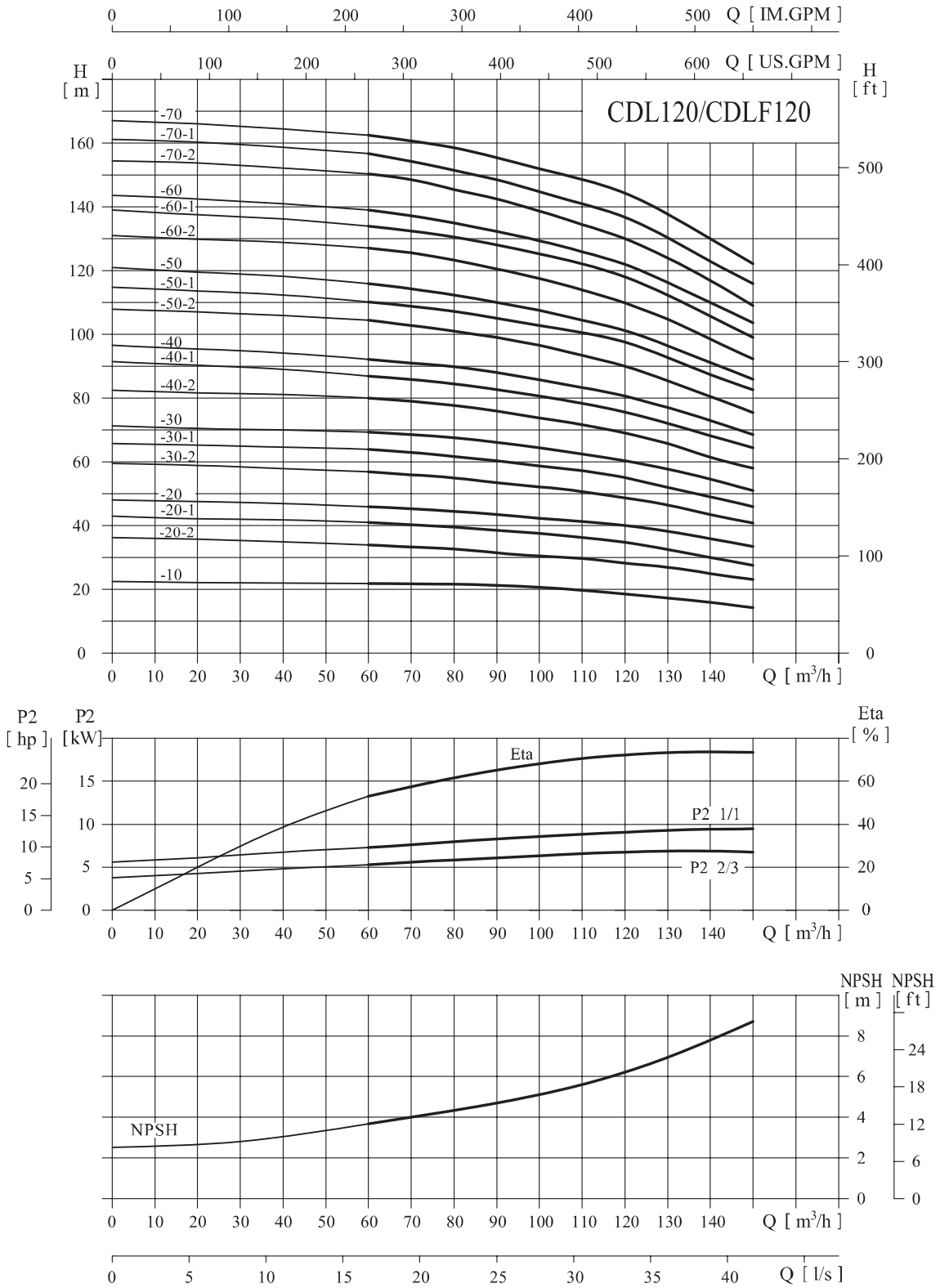

技术数据

性能表

型号	配用电机 (kW)	Q (m ³ /h)	H (m)									
			60	70	80	90	100	110	120	130	140	150
CDL120-10	11	H (m)	22	21.8	21.6	21	20.5	19.5	18.5	17	16	15
CDL120-20-2	15		34	33.6	33	31	30.2	30	28.5	27	25	24
CDL120-20-1	18.5		41	40	39.5	38.5	37	36.5	34.5	32.5	30	27.5
CDL120-20	22		46	45	44.5	43.5	42.4	41	40	38	36	33.5
CDL120-30-2	30		57	56	55	53.5	52	51	49	46.5	43.5	41
CDL120-30-1	30		64	63	62	60	58.5	57.5	55.5	52	49	46
CDL120-30	30		69.5	68.5	67.5	66	64.4	62.5	61	57.5	54.5	51
CDL120-40-2	37		80.5	79	78	76	73.5	72	69	66	61.5	58
CDL120-40-1	37		87	86	84.5	82	80	78	76	72	68	64.5
CDL120-40	45		92.5	91	90	88	85.5	83	81	77	73	68.5
CDL120-50-2	45		104.5	103	101	99	96	93	90	85.5	80.5	75.5
CDL120-50-1	45		110.5	109	107.5	105	102	100	97	92	86.5	83
CDL120-50	55		115.5	114	113	110	107.5	104.5	101.5	96	91	86
CDL120-60-2	55		128	125.5	123	121	117.3	113.5	110	104.5	98.5	92.5
CDL120-60-1	55		134	132	130.5	127	124	121	118	111	105	100
CDL120-60	75		139	137	135	132	128.8	126	123	116	110	104
CDL120-70-2	75		151	148	145.5	143	138.6	134	130	123.5	116.5	109
CDL120-70-1	75		156.5	154	152	148.5	144.5	141	137.5	130	123	116.5
CDL120-70	75		162.5	160.5	158.5	155	151	148	145	137	129	123

安装图

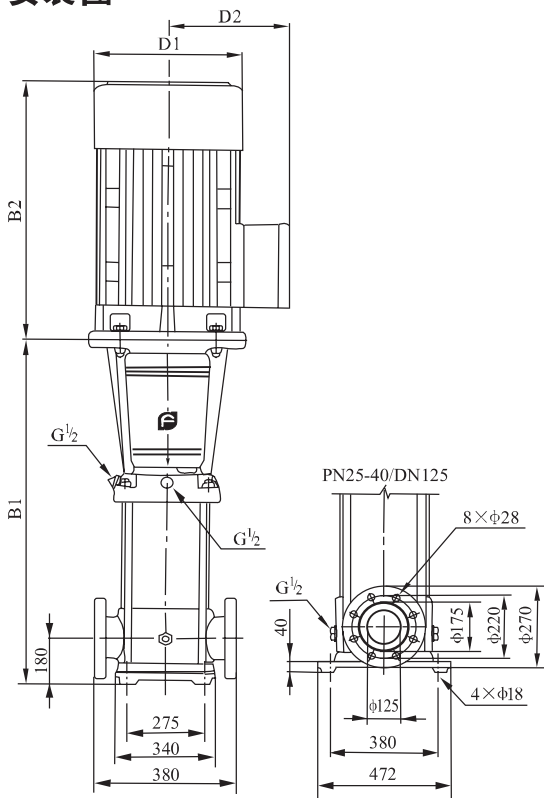

尺寸和重量

型号	尺寸(mm)					重量(kg)
	B1	B2	B1+B2	D1	D2	
CDL120-10	840	500	1340	330	255	230
CDL120-20-2	1000	500	1500	330	255	245
CDL120-20-1	1000	550	1550	330	255	250
CDL120-20	1000	575	1575	360	285	285
CDL120-30-2	1160	650	1810	400	310	360
CDL120-30-1	1160	650	1810	400	310	360
CDL120-30	1160	650	1810	400	310	360
CDL120-40-2	1320	650	1970	400	310	400
CDL120-40-1	1320	650	1970	400	310	400
CDL120-40	1320	685	2005	460	340	460
CDL120-50-2	1480	685	2165	460	340	470
CDL120-50-1	1480	685	2165	460	340	470
CDL120-50	1510	760	2270	540	370	575
CDL120-60-2	1670	760	2430	540	370	585
CDL120-60-1	1670	760	2430	540	370	585
CDL120-60	1670	845	2515	580	410	705
CDL120-70-2	1830	845	2675	580	410	715
CDL120-70-1	1830	845	2675	580	410	715
CDL120-70	1830	845	2675	580	410	715

隔爆电机外形尺寸有所变动, 详情请咨询本公司。

性能曲线

2950rpm

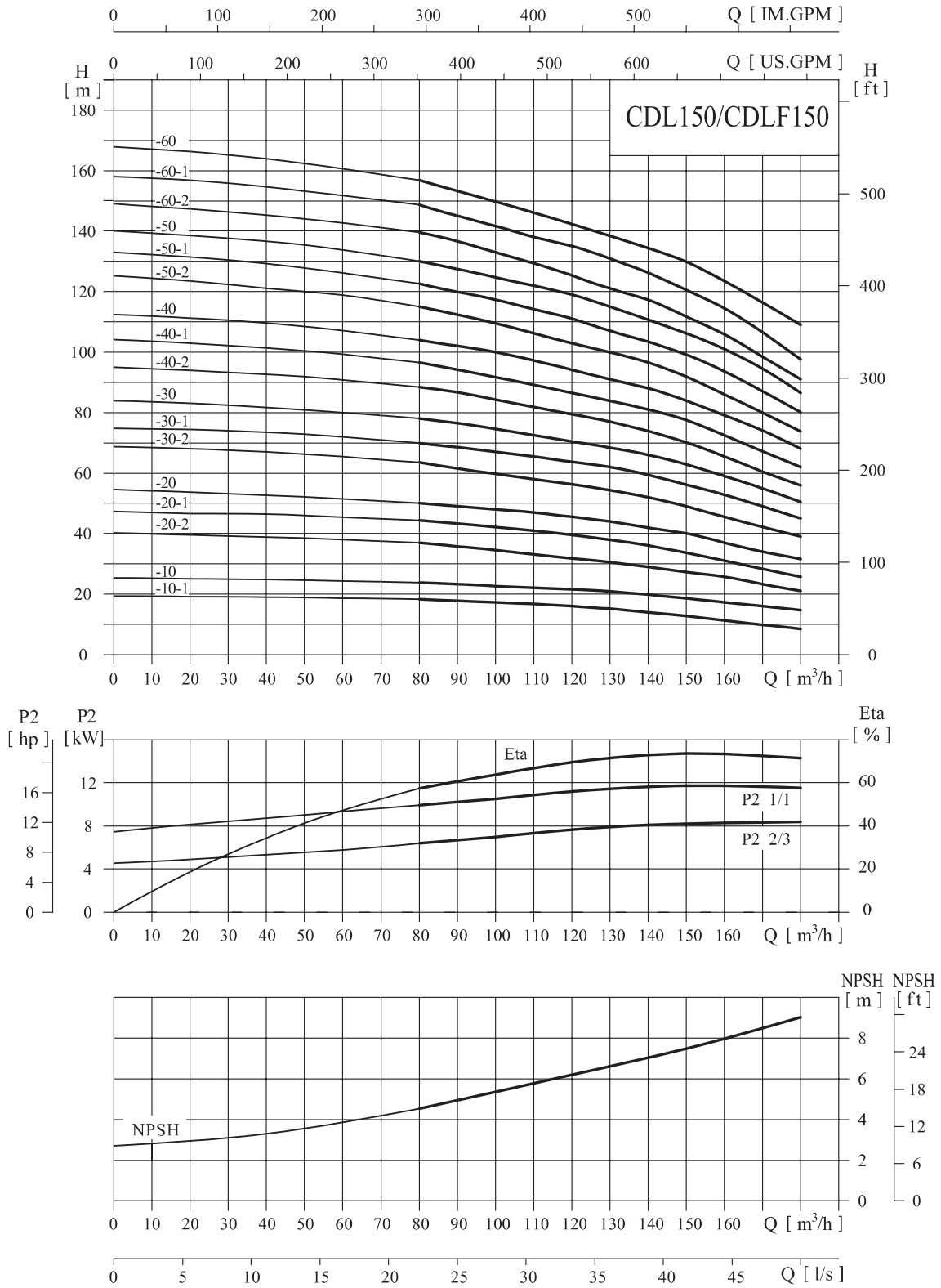

技术数据

性能表

型号	配用电机 (kW)	Q (m ³ /h)	H (m)										
			80	90	100	110	120	130	140	150	160	170	180
CDL150-10-1	11	H (m)	18.3	17.8	17.3	17	16	15	14	12.5	11	10	8.5
CDL150-10	15		24	23	22.5	22	21.5	20.5	20	18.5	17	16	15
CDL150-20-2	18.5		37	35.5	34	33	32	31	29	27.5	26	23	21
CDL150-20-1	22		44.3	43	42	40	39	38.5	37.5	35	33	30	27
CDL150-20	30		50	49	48	47	45.5	44	42	40	37	34	32
CDL150-30-2	30		63.5	61	59	57.5	56	54.5	53	49	45.5	42	39
CDL150-30-1	37		70	68	67	65	63	62	60	56	53	49	45
CDL150-30	37		78	76.5	75	73	70.5	68	66	63	59	55	50.5
CDL150-40-2	45		89	87	84	81.5	79	77	74.5	70.5	65.5	60	56
CDL150-40-1	45		96.5	94	91.5	89	86.5	84	81.5	77	72.5	67	62
CDL150-40	55		104	102	100	97	95	91	88	84	79.5	74	68
CDL150-50-2	55		115.5	112	109	106	102.5	100	97	92	86	79	73.5
CDL150-50-1	75		122.5	119.5	117	113.5	111.5	107.5	104.5	99	93.5	87	80
CDL150-50	75		130	127.5	125	121	119	115	111.5	106.5	101	94.5	86.5
CDL150-60-2	75		140	137	133	130	126	121	118	112	106	98	91
CDL150-60-1	75		148.5	145	141.7	137.5	135	131	127	120.5	114.5	106.5	97.5
CDL150-60	75		157	153	149	145	142	139.5	137	130	123.5	116	109

安装图

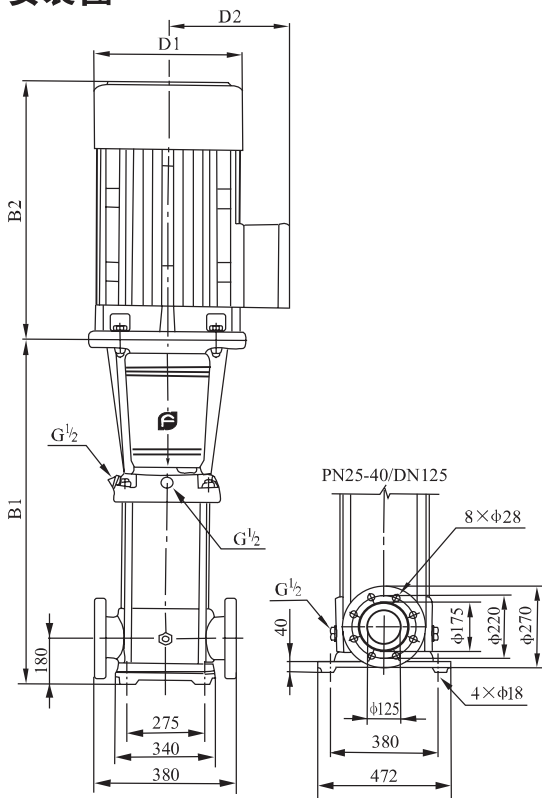

尺寸和重量

型号	尺寸(mm)					重量(kg)
	B1	B2	B1+B2	D1	D2	
CDL150-10-1	840	500	1340	330	255	230
CDL150-10	840	500	1340	330	255	235
CDL150-20-2	1000	550	1550	330	255	250
CDL150-20-1	1000	575	1575	360	285	295
CDL150-20	1000	650	1650	400	310	350
CDL150-30-2	1160	650	1810	400	310	360
CDL150-30-1	1160	650	1810	400	310	360
CDL150-30	1160	650	1810	400	310	385
CDL150-40-2	1320	685	2005	460	340	460
CDL150-40-1	1320	685	2005	460	340	460
CDL150-40	1350	760	2110	540	370	560
CDL150-50-2	1510	760	2270	540	370	570
CDL150-50-1	1510	845	2355	580	410	690
CDL150-50	1510	845	2355	580	410	690
CDL150-60-2	1670	845	2515	580	410	700
CDL150-60-1	1670	845	2515	580	410	700
CDL150-60	1670	845	2515	580	410	700

隔爆电机外形尺寸有所变动，详情请咨询本公司。

性能曲线

2950rpm

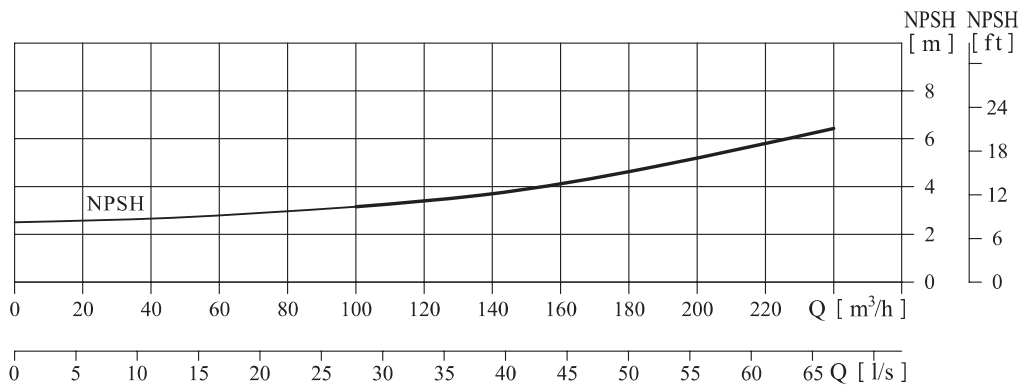
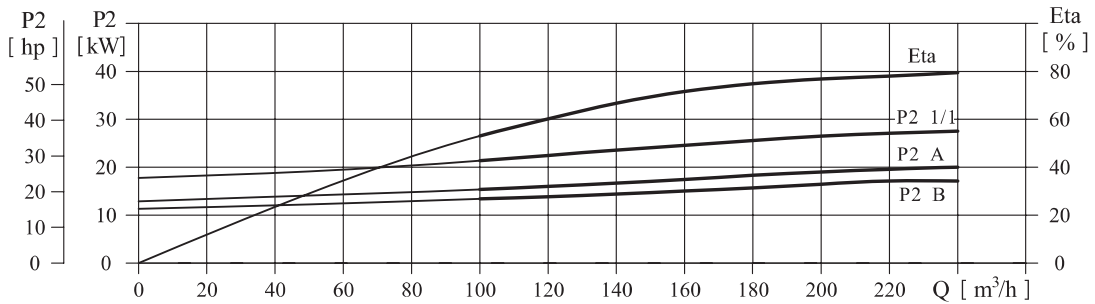
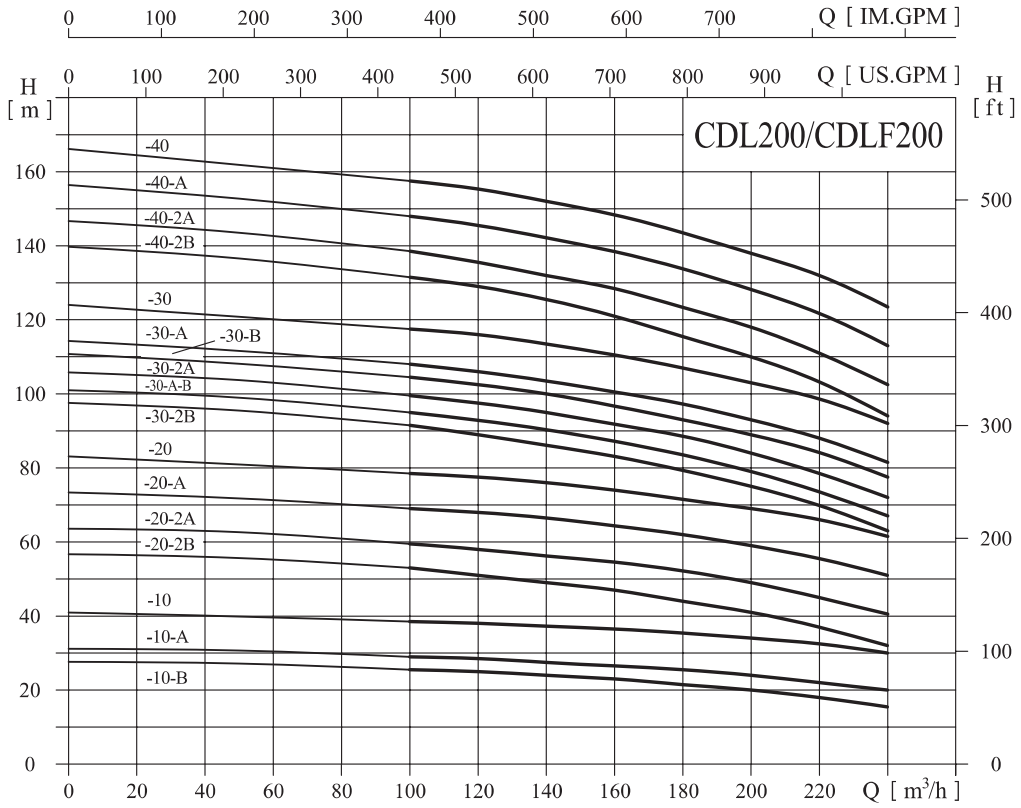

技术数据

性能表

型号	配用电机 (kW)	Q (m ³ /h)	H (m)							
			100	120	140	160	180	200	220	240
CDL200-10-B	18.5	H	25.5	25	24	23	21.5	20	18	15.5
CDL200-10-A	22		29	28.5	27.5	26.5	25.5	24	22	20
CDL200-10	30		38.5	38	37.5	36.5	35	34	32.5	30
CDL200-20-2B	37		53	51	49	47	44	41	37	32
CDL200-20-2A	45		59.5	58	56	54	52.5	49	44.5	40.5
CDL200-20-A	55		69	68	66	64	62	59	55.5	51
CDL200-20	55		78.5	77.5	76	74	71.5	69	66	61.5
CDL200-30-2B	75		91.5	89	86.5	83.5	79	75	70	63
CDL200-30-A-B	75		95	93	90	87	83.5	79	73.5	67
CDL200-30-2A	75		99.5	97.5	94.5	91.5	89	84	78.5	72
CDL200-30-B	75		104.5	102.5	100	97	93	89	84.5	77.5
CDL200-30-A	75		108	106	103.5	100.5	97.5	93	88	81.5
CDL200-30	90		117.5	116	113.5	110.5	107	103	99	92
CDL200-40-2B	90		131.5	129	125.5	121	115.5	110	103.5	94
CDL200-40-2A	110		138.5	136	132	128	124	118	111	102.5
CDL200-40-A	110		148	145.5	142.5	138	134	128	122	113
CDL200-40	110		157.5	155.5	152.5	148	143.5	138	132.5	123.5

安装图

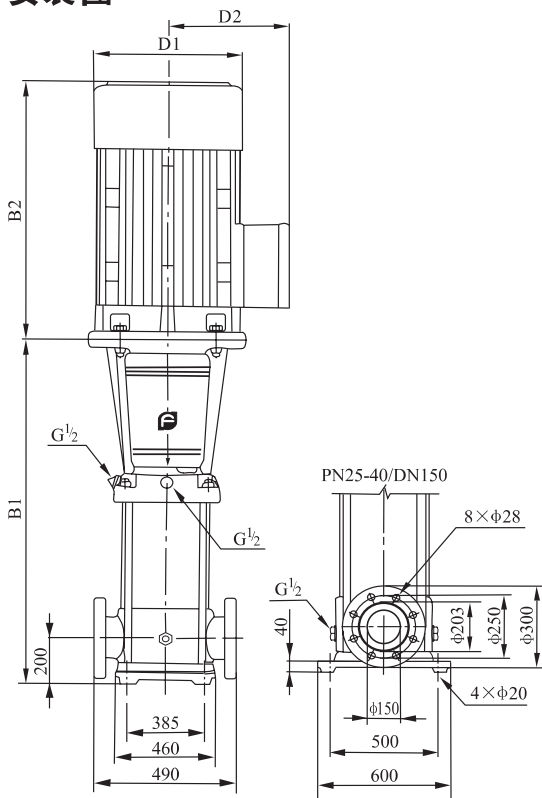

尺寸和重量

型号	尺寸(mm)					重量(kg)
	B1	B2	B1+B2	D1	D2	
CDL200-10-B	907	550	1457	330	255	311
CDL200-10-A	907	575	1482	360	285	347
CDL200-10	907	650	1557	400	310	403
CDL200-20-2B	1101	650	1751	400	310	447
CDL200-20-2A	1101	685	1786	460	340	504
CDL200-20-A	1131	760	1891	540	370	595
CDL200-20	1131	760	1891	540	370	595
CDL200-30-2B	1325	845	2170	580	410	748
CDL200-30-A-B	1325	845	2170	580	410	748
CDL200-30-2A	1325	845	2170	580	410	748
CDL200-30-B	1325	845	2170	580	410	748
CDL200-30-A	1325	845	2170	580	410	748
CDL200-30	1325	895	2220	580	410	817
CDL200-40-2B	1519	895	2414	580	410	830
CDL200-40-2A	1519	1140	2659	645	550	1180
CDL200-40-A	1519	1140	2659	645	550	1180
CDL200-40	1519	1140	2659	645	550	1180

隔爆电机外形尺寸有所变动, 详情请咨询本公司。